

3942500COM 3 In 1 Media Dresser

**NOV
OGR
ATZ**

Date of Purchase ___ / ___ / ___
Lot Number:

B343942500COM0

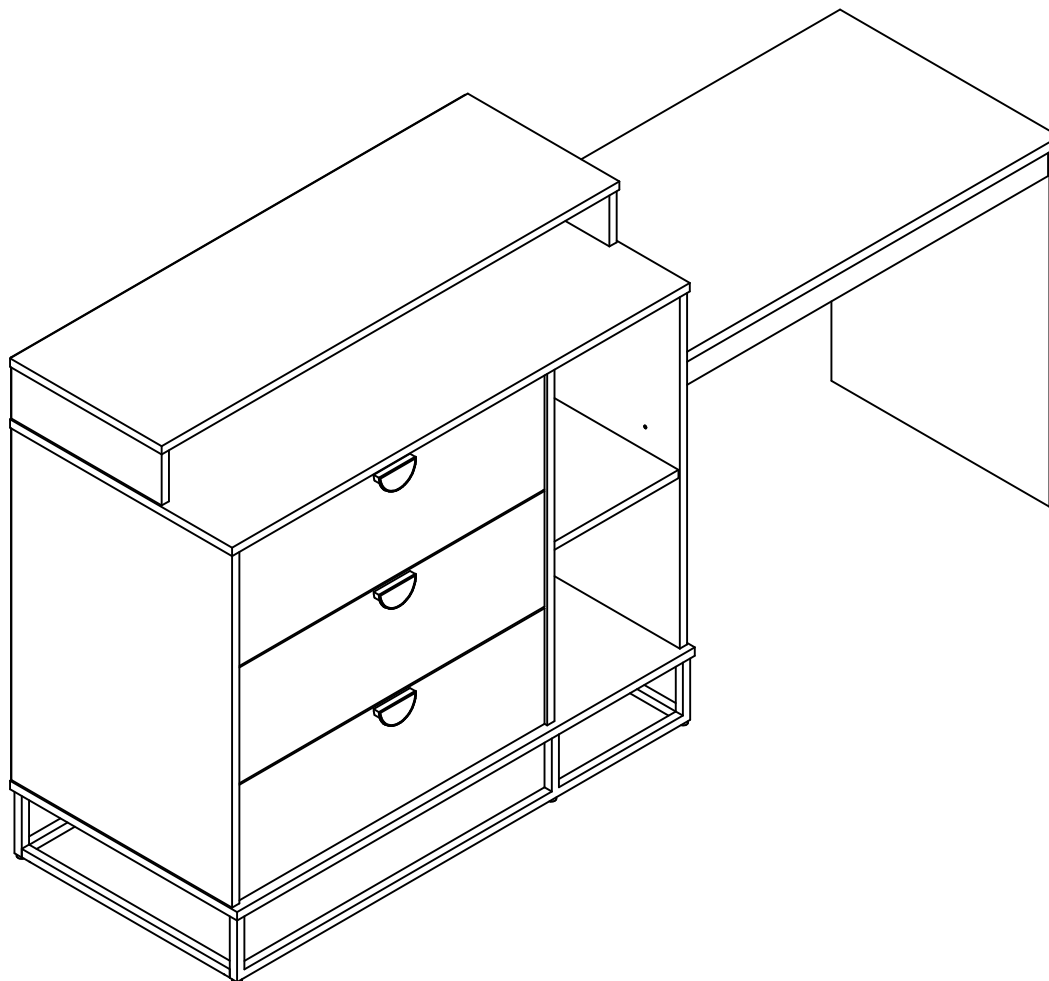

Do Not Return This Product!
Contact our customer service team for help first.
Call: 1-800-489-3351 (toll free)
Monday-Friday 9am - 5pm CST
Visit: www.ameriwoodhome.com

THIS INSTRUCTION BOOKLET CONTAINS **IMPORTANT** SAFETY INFORMATION. PLEASE READ AND KEEP FOR FUTURE REFERENCE.

Secure Your Furniture

Keep your home and family safe with the wall anchor kit that is included with the product.

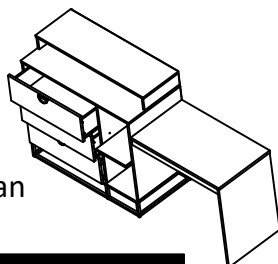

Serious or fatal crushing injuries can occur from tipping furniture.

WARNING: Manufacturer assumes no liability for improper installation or excessive loads placed on screws or bracket. This wall anchor is not a substitute for proper adult supervision.



Follow Ameriwood Home



Contact Us!

Do NOT return this product!

Contact our friendly customer service team first for help.

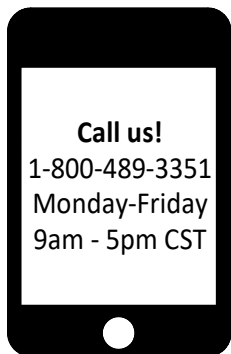

Visit ameriwoodhome.com to view the limited warranty valid in the U.S. and Canada.

Assembly Tips



Helpful Hints

PEOPLE NEEDED FOR ASSEMBLY: 1-2

- Open your item in the area you plan to keep it to avoid excessive heavy lifting.
- Identify, sort and count the parts before attempting assembly.
- Compression dowels are lightly tapped in with a hammer.
- Slides are labeled with a **R** (right) and **L** (left) for proper placement.
- Make sure to always face the point on the top of the Cam Lock towards the outer edge.
- Use all the nails provided for the back panel and spread them out equally.
- Back panel must be used to make sure your unit is sturdy.
- Do NOT use harsh chemicals or abrasive cleaners on this item.
- Never push, pull, or drag your furniture.

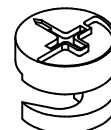

Before You Start

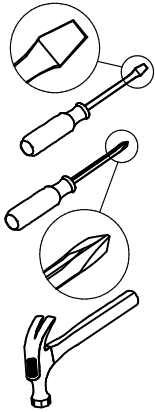
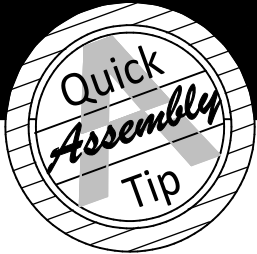

- ✓ Read through each step carefully and follow the proper order
- ✓ Separate and count all your parts and hardware
Parts are labeled on the surface or edge of the part
- ✓ Give yourself enough room for the assembly process
- ✓ Have the following tools: Flat Head Screwdriver, #2 Phillips Head Screwdriver and Hammer
- ✓ Caution: If using a power drill or power screwdriver for screwing, please be aware to slow down and stop when screw is tight. Failure to do so may result in stripping the screw.

Cam Lock Fastening System

This Cam Lock Fastening System will be used throughout the assembly process.

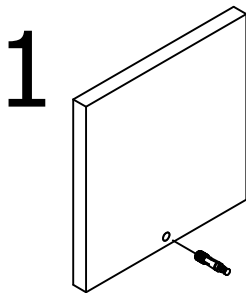

Press CAM BOLT into hole.

2

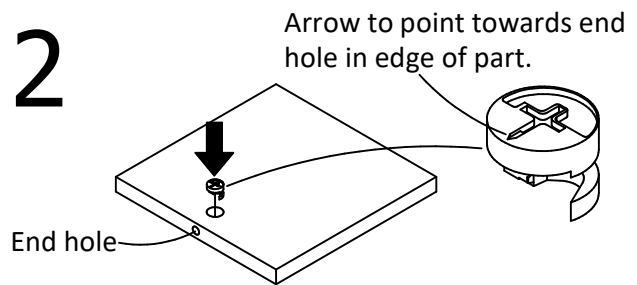

Press CAM LOCK into hole.

3

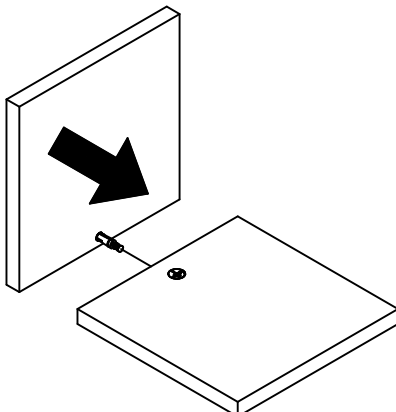

Press parts together so CAM BOLT inserts into edge hole.

4

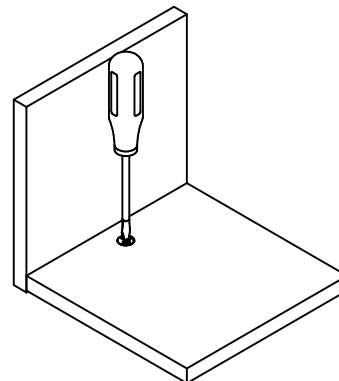

Using a screwdriver, turn the CAM LOCK clockwise to lock the CAM LOCK and CAM BOLT into their holes and fastening parts together.

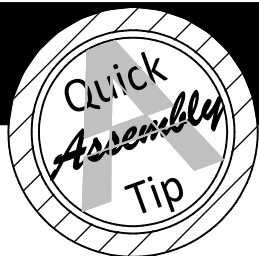

Before You Start

Please Note:

You may need to lightly tap the wood dowels into the holes during your assembly process.

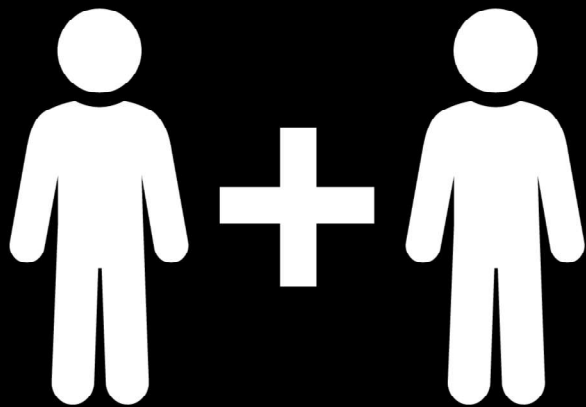
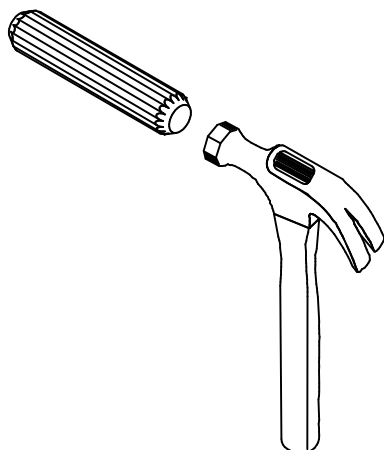

2 PEOPLE NEEDED FOR ASSEMBLY

**2 PERSONAS NECESITADAS
PARA LA ASAMBLEA**

**2 PERSONNES NÉCESSAIRES
POUR L'ASSEMBLAGE**

CAUTION: Failure to use 2 people for assembly could result in unit damage or personal injury.

PRECAUCIÓN: Si no se utilizan 2 personas para el ensamblaje, se pueden producir daños en la unidad o lesiones personales.

ATTENTION: Échec d'utiliser 2 personnes pour l'assemblage peut causer du dommage au meuble ou causer des blessures.

Board Identification

Not actual size

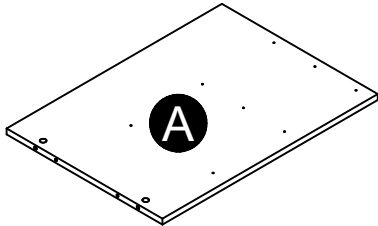

Left Panel
33942306010

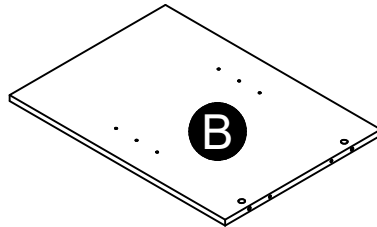

Right Panel
33942306020

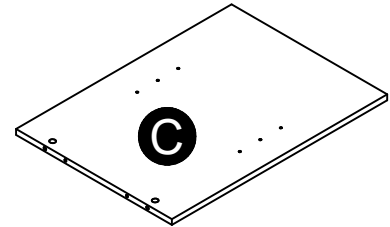

Partition
33942306030

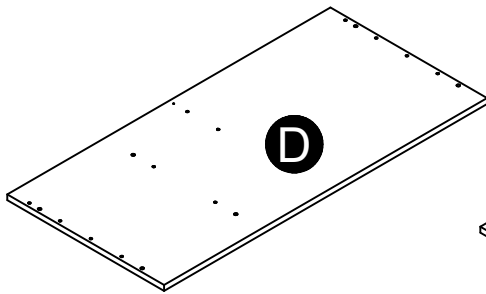

Top
33942306040

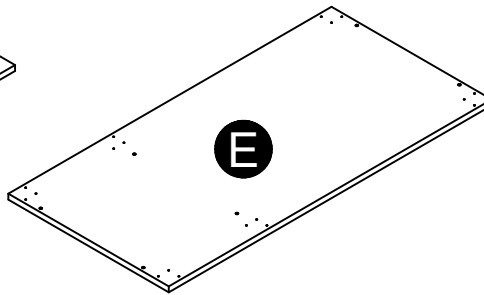

Bottom
33942306050

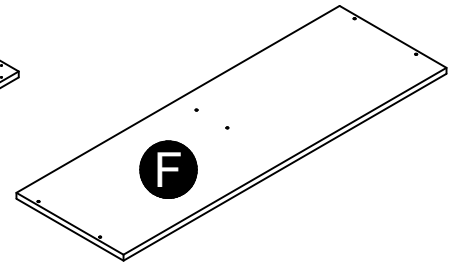

Hutch Top
33942306060

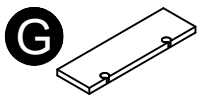

Left Hutch Panel
33942306070

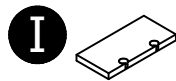

Hutch Partition
33942306090

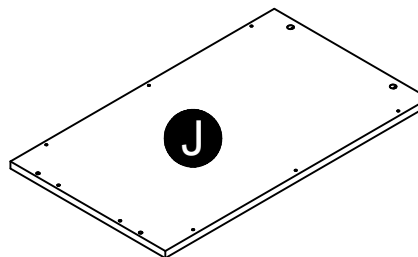

Desk Top
33942306100

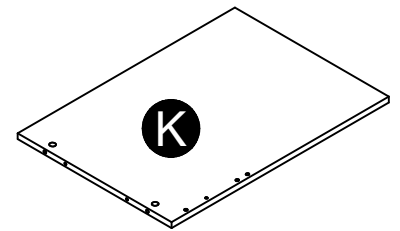

Desk Panel
33942306110

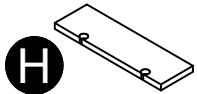

Right Hutch Panel
33942306080

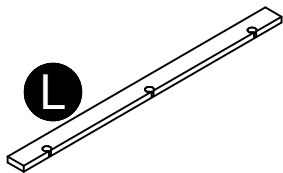

Desk Rail
33942306120

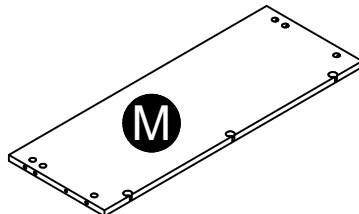

Modesty Panel
33942306130

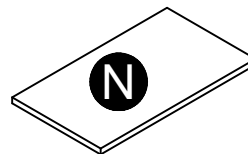

Adjustable Shelf
33942306140

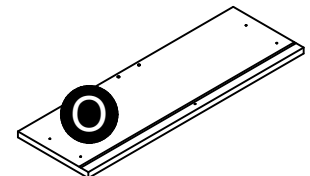

Drawer Front (x3)
33942319150

Board Identification

Not actual size

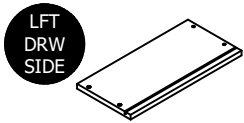

Left Drawer Side (x3)
39991167346410L



Right Drawer Side (x3)
39991167346410R

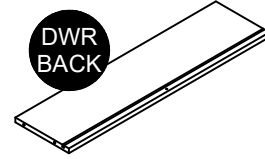

Drawer Back (x3)
39991167062618B

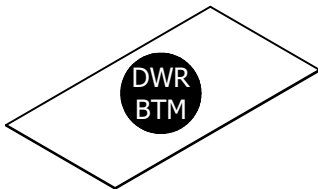

Drawer Bottom (x3)
39991340063710D

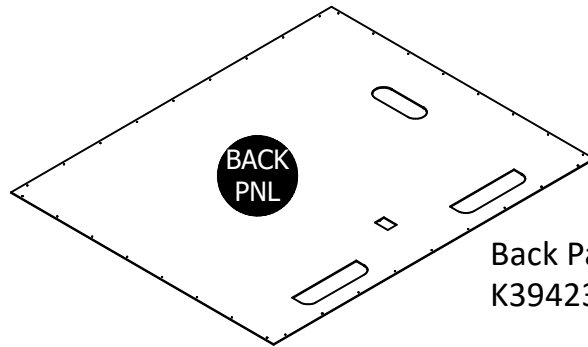

Back Panel
K394230600

This piece is paperboard construction. It is not made from wood, but is required for the assembly of your unit.

Board Identification

Not actual size

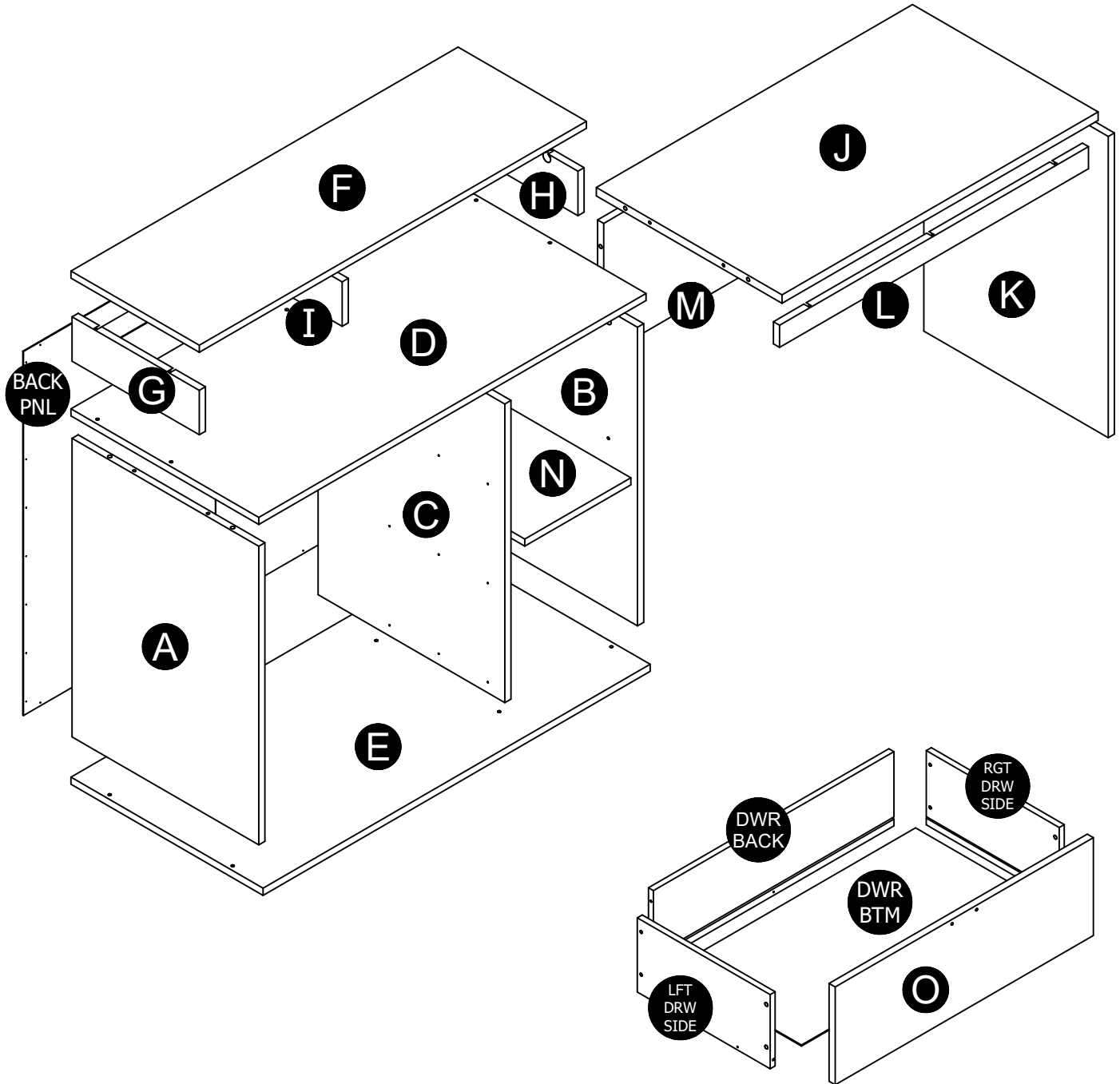

Part List

Actual Size

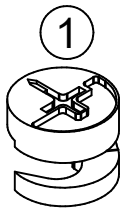

(x16)
#A22700
cam lock

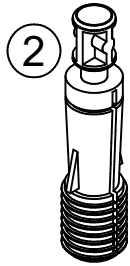

(x16)
#A22710
cam bolt

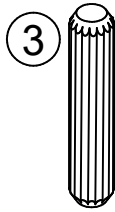

(x12)
#A21670
wood dowel

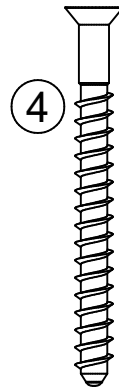

(x12)
#A23030
confirmat screw



(x12)
#A22910
connector bolt

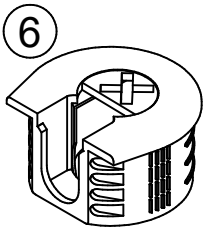

(x12)
#A22900
connector



(x30)
#A11080
7/16" screw

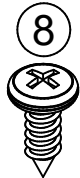

(x16)
#A14220
1/2" screw

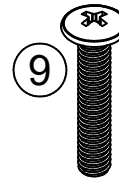

(x6)
#A17400
7/8" bolt

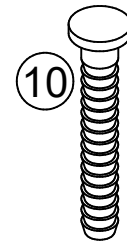

(x12)
#A21975
drive fastener



(x30)
#A12120
7/16" screw

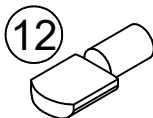

(x4)
#A80250
shelf support

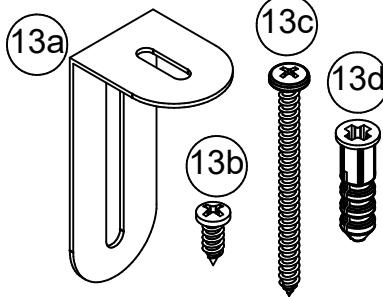

(x1)
#A84050
safety bracket



(x34)
#A21110
nail

Part List

Not Actual Size

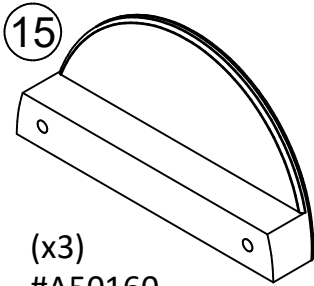

(x3)
#A50160
handle

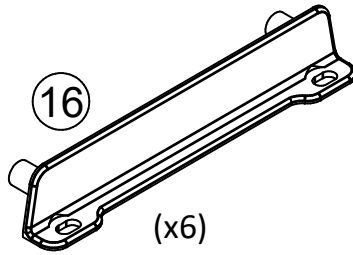

(x6)
#A54520
drawer bracket

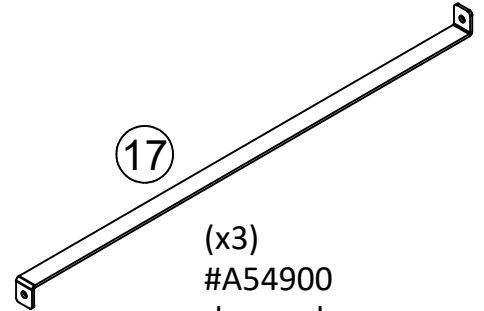

(x3)
#A54900
drawer brace

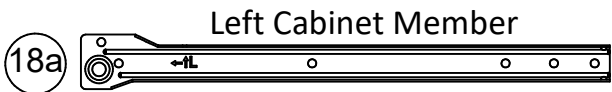

Left Cabinet Member

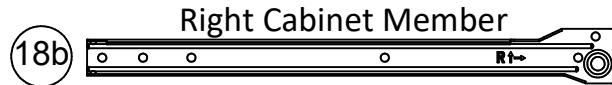

Right Cabinet Member

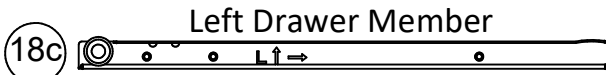

Left Drawer Member

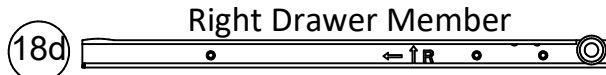

Right Drawer Member

(x3)
#A56770
slide

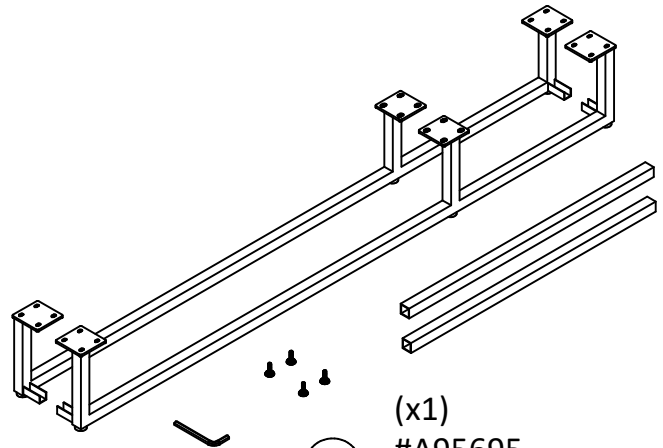

(x1)
#A95695
metal base kit

STEP 1

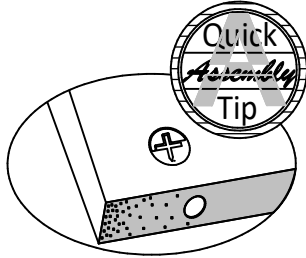
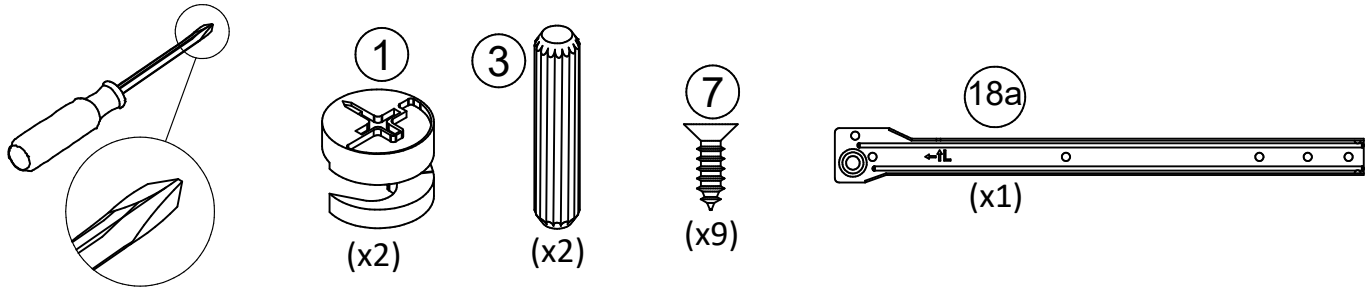

Proper orientation of CAM LOCK

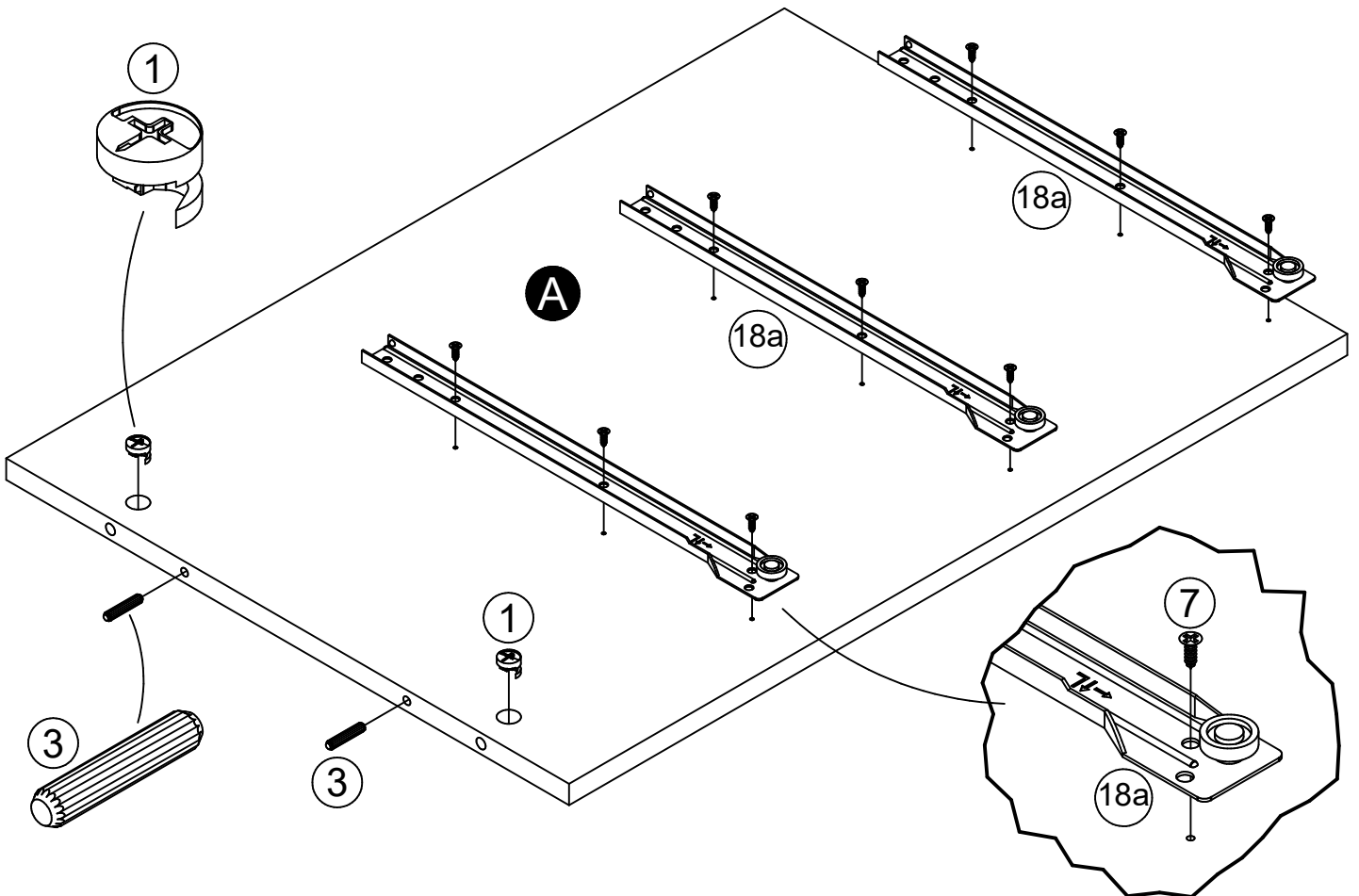

STEP 2

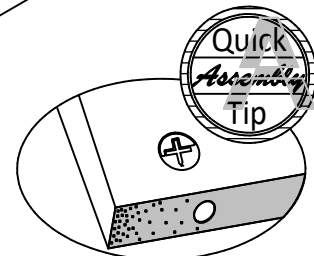
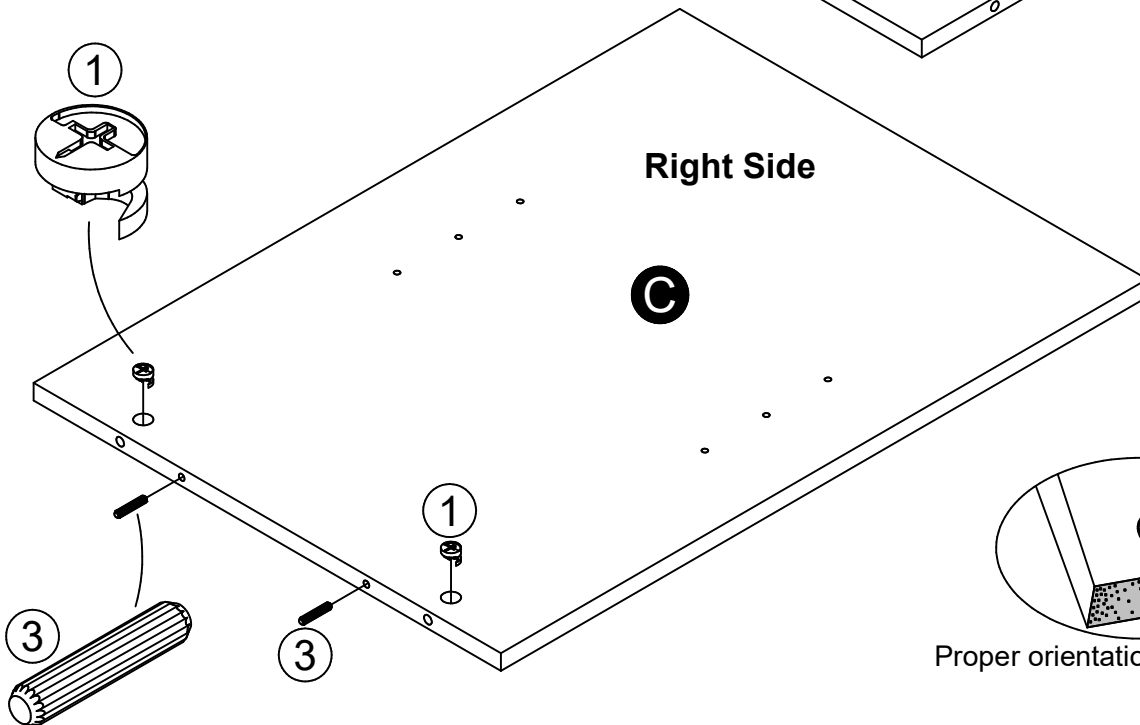
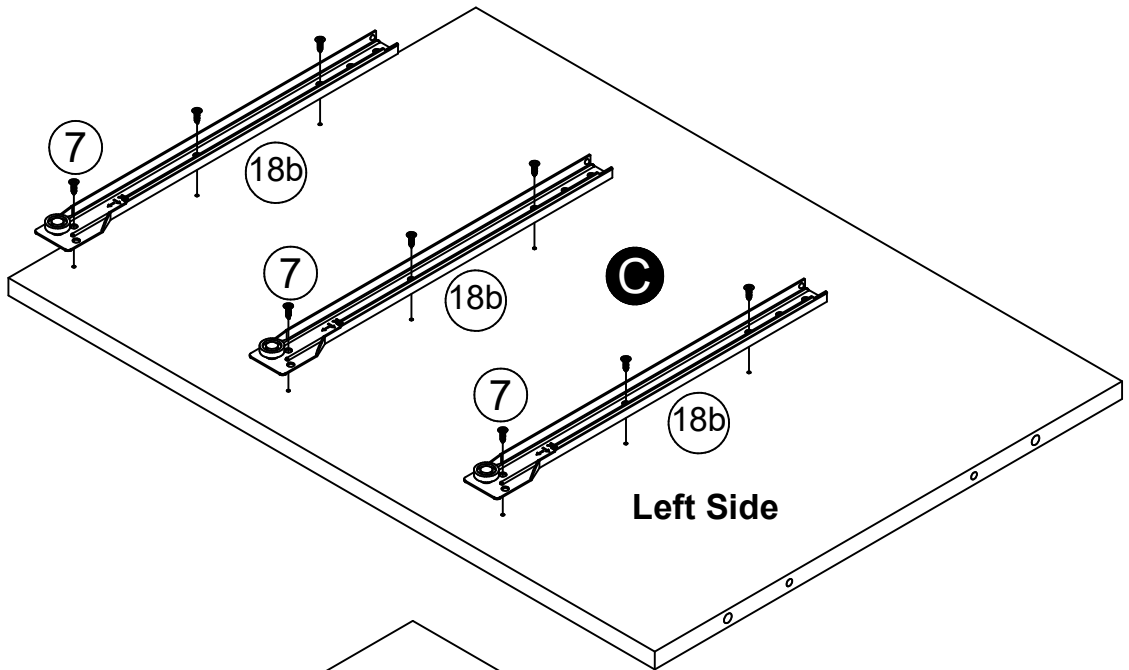
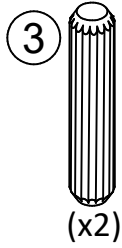
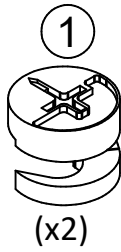
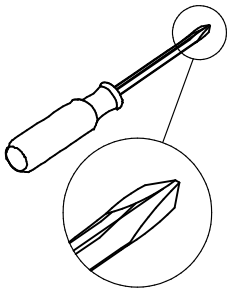

STEP 3

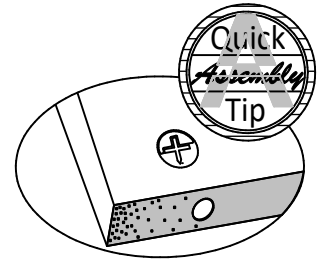
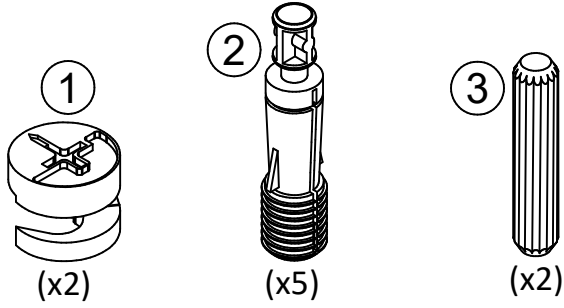

Proper orientation of CAM LOCK

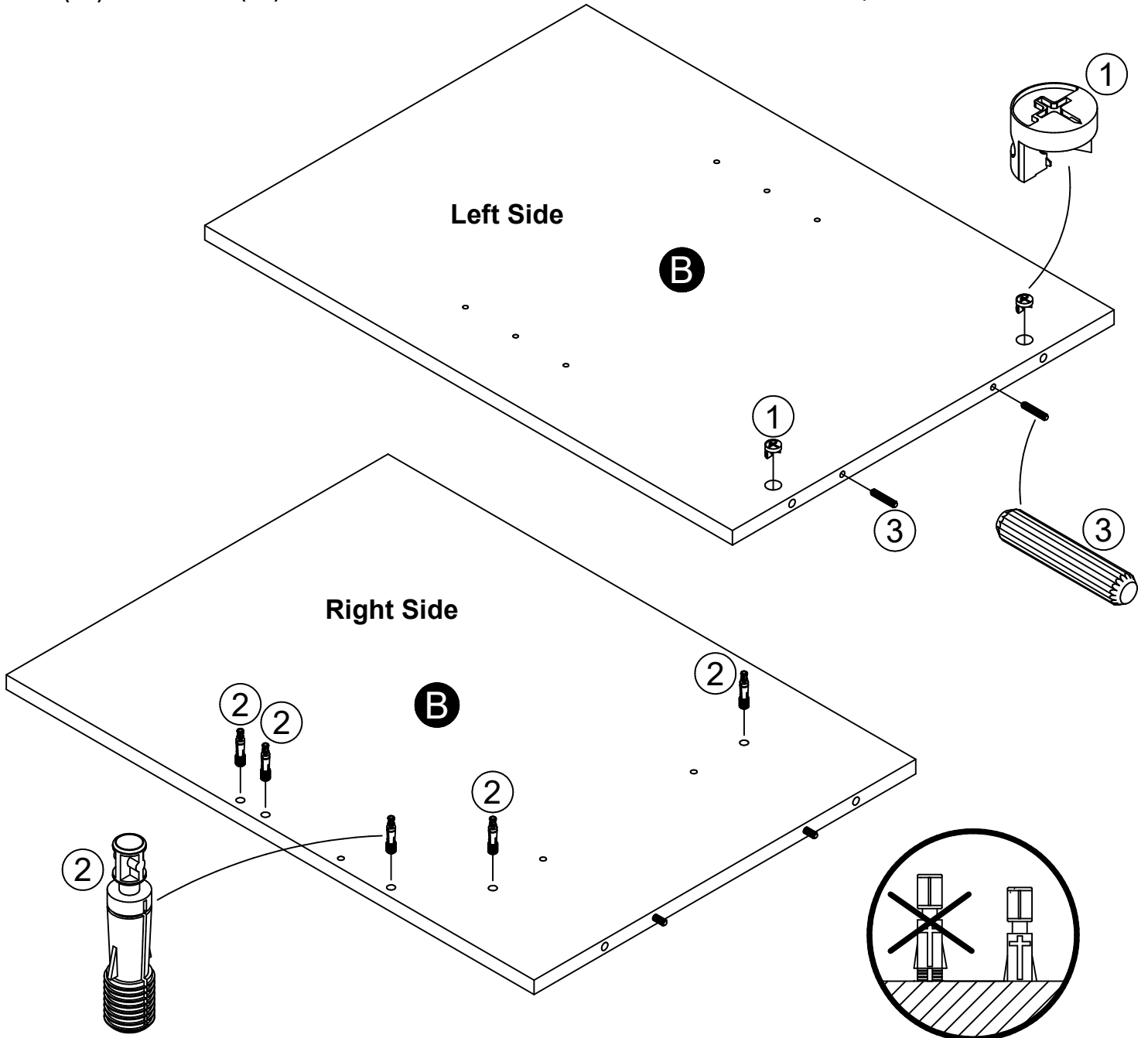

STEP 4

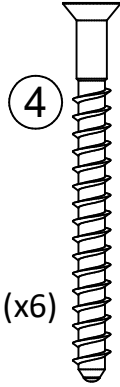
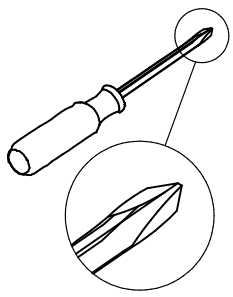

Finished Edges Face Up

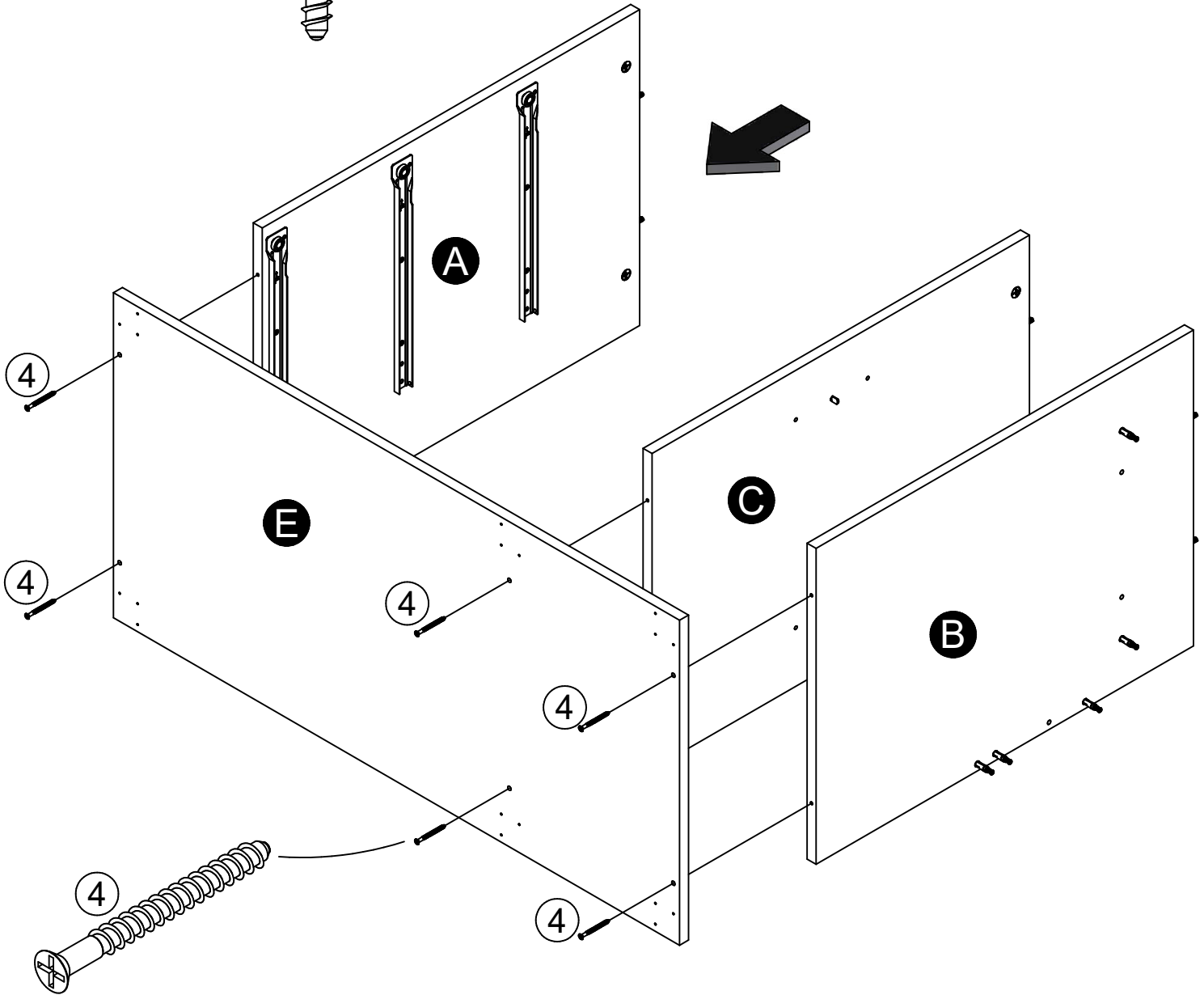

STEP 5

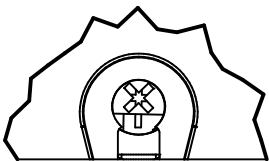
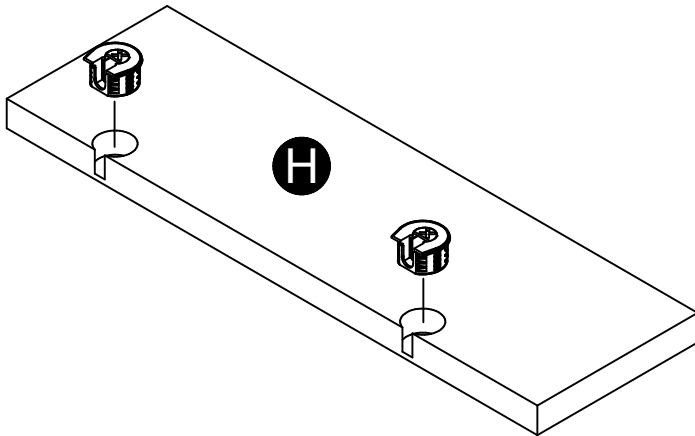
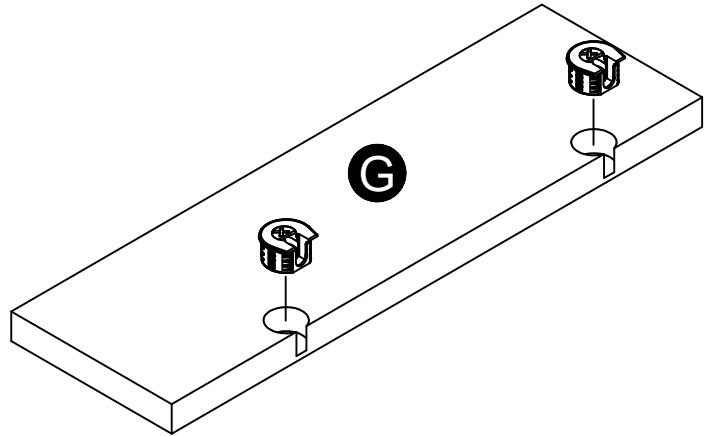
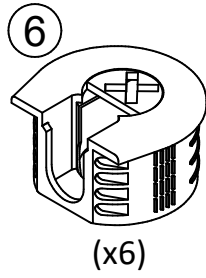
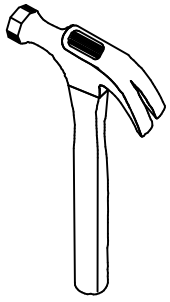

Position Connector (6) as shown
Tap Connector into hole using a hammer.

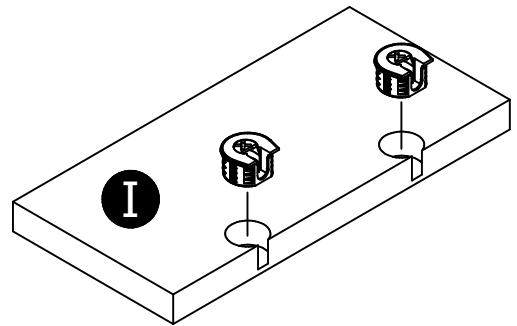

STEP 6

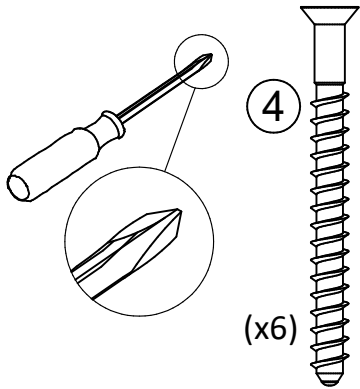

Finished Edges Face Up

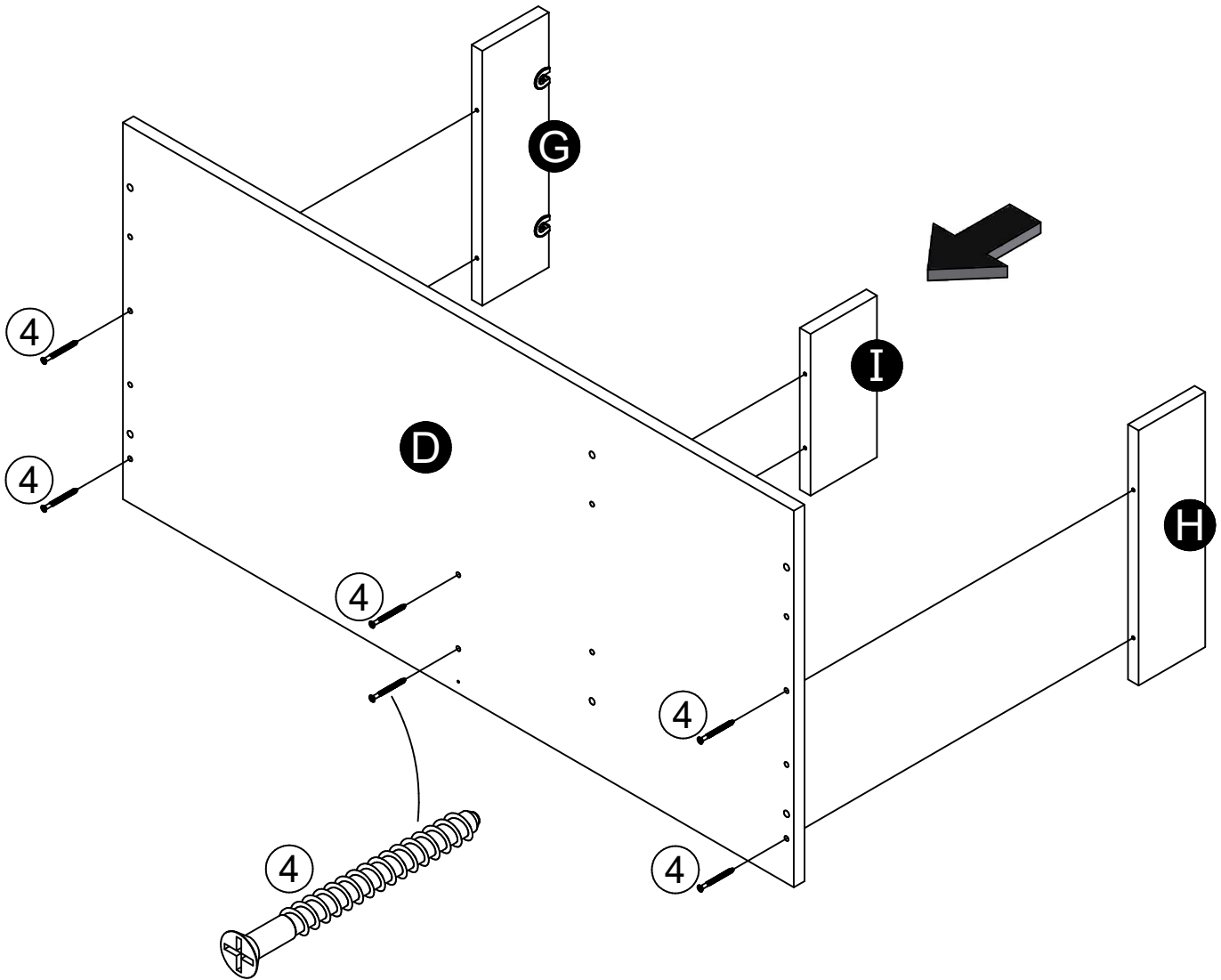

STEP 7

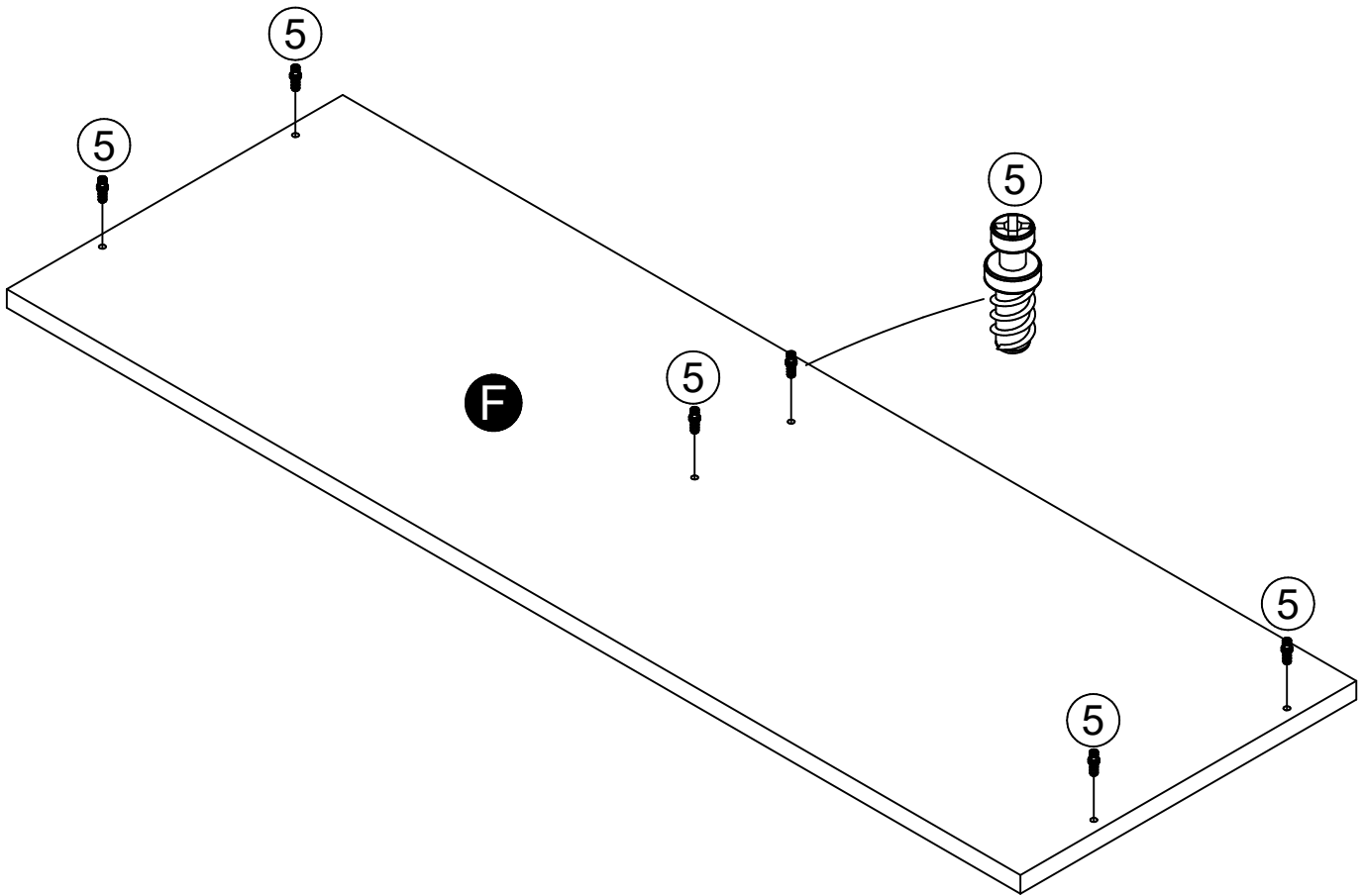
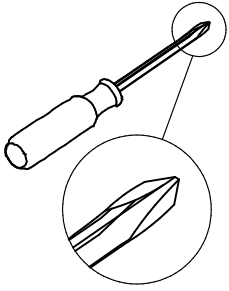

STEP 8

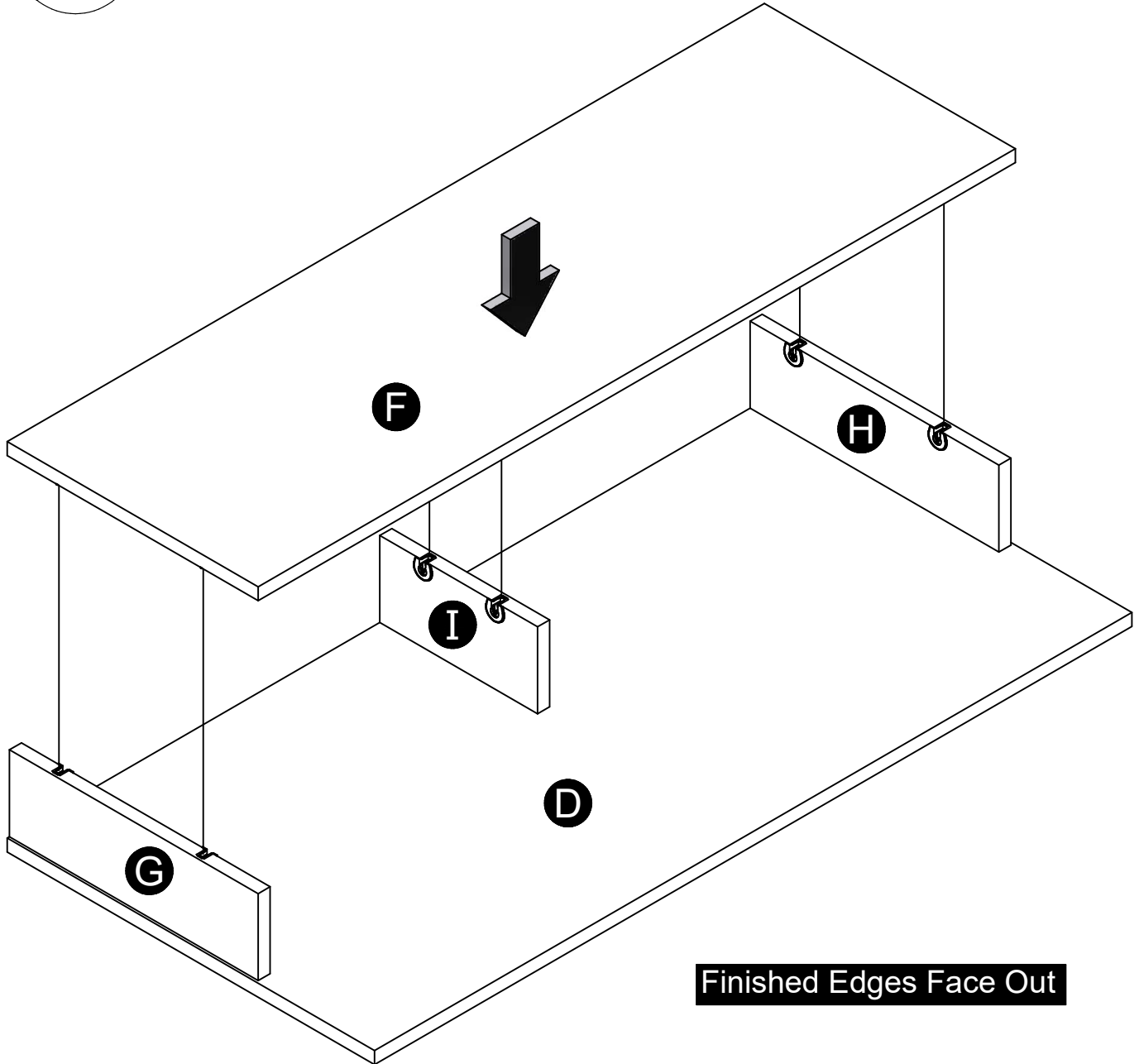
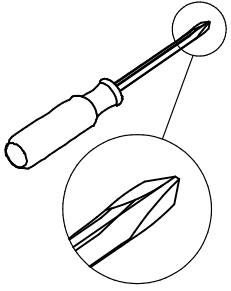

STEP 9

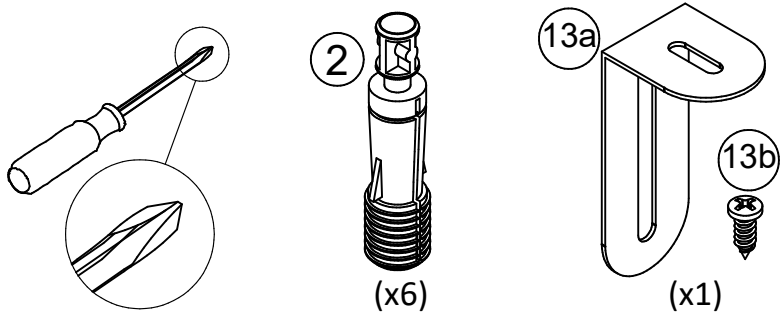

Do not fully tighten this screw.

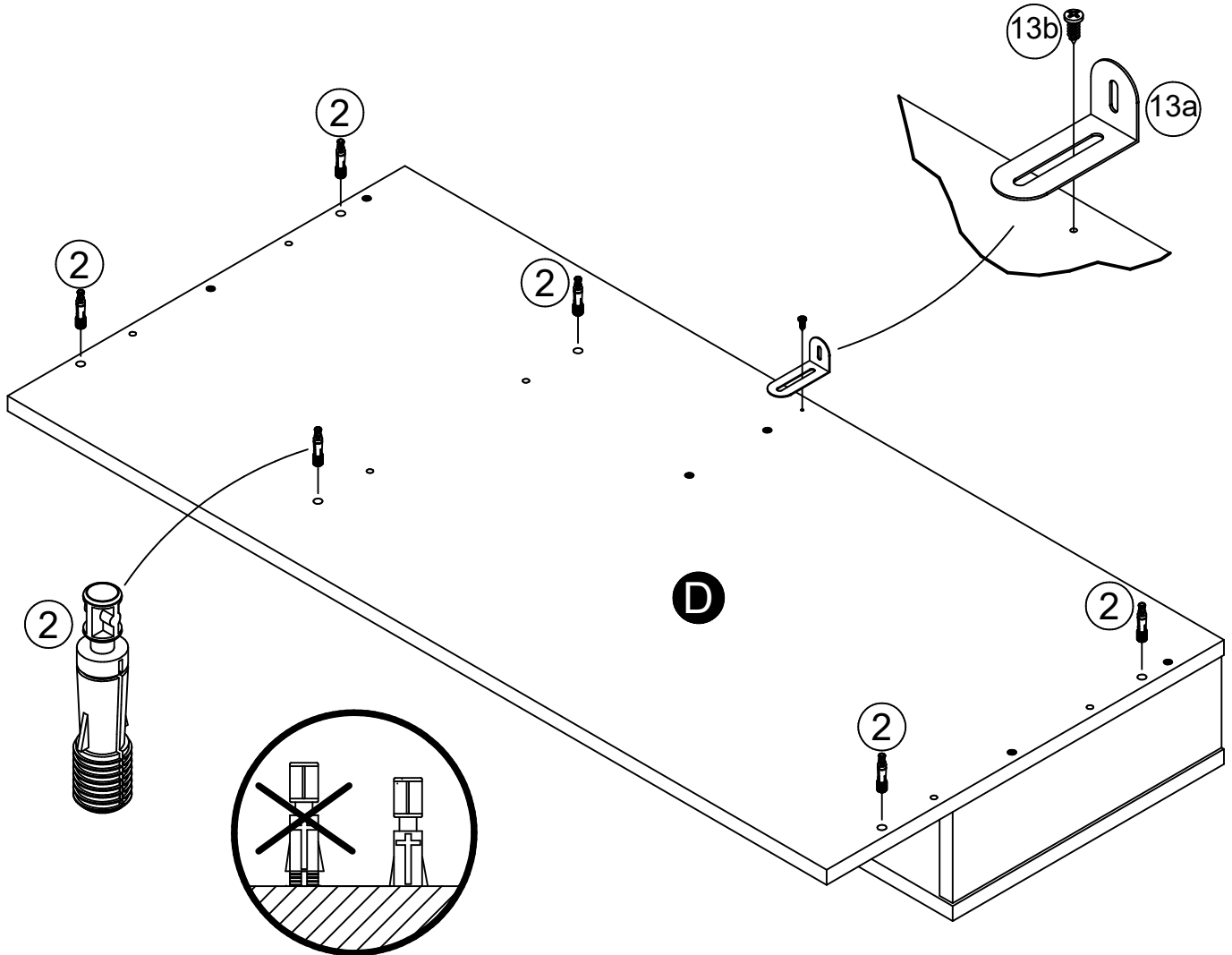

STEP 10

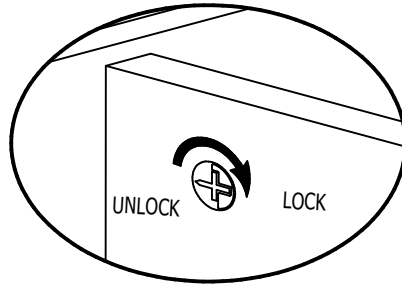
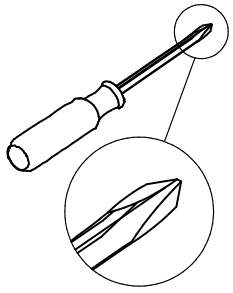

Finished Edges Face Up

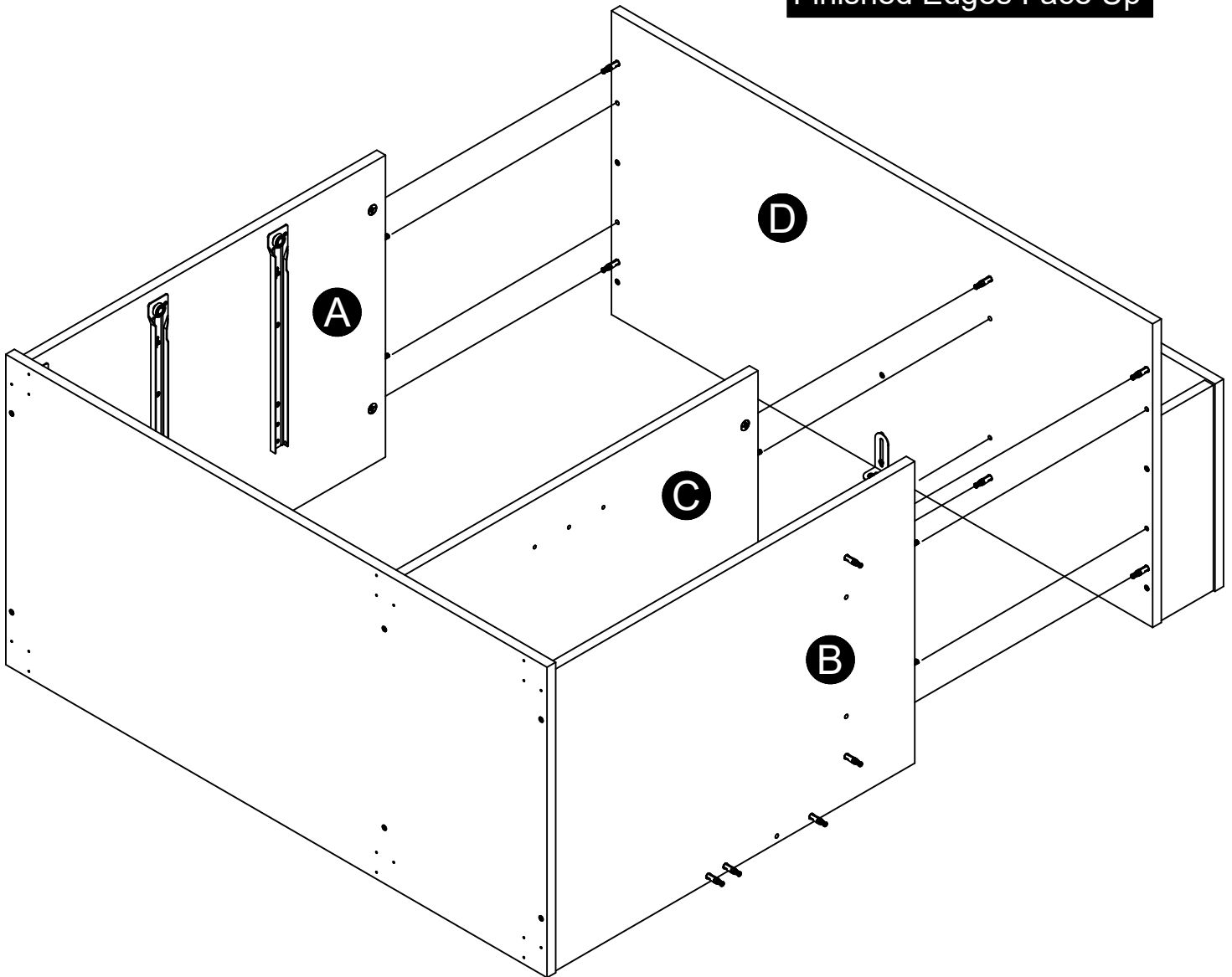

STEP 11

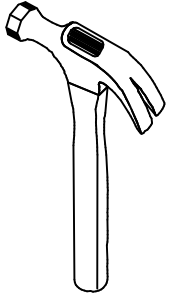

14

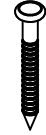

(x34)

IMPORTANT! THE BACK PANEL IS A STRUCTURAL PART OF THIS UNIT AND MUST BE INSTALLED PROPERLY.

Carefully turn the unit onto its front side.
Attached the back panel as shown nailing straight into the raw edges.
Assure that the unit is square.
Distance from corner to corner must be equal as shown.

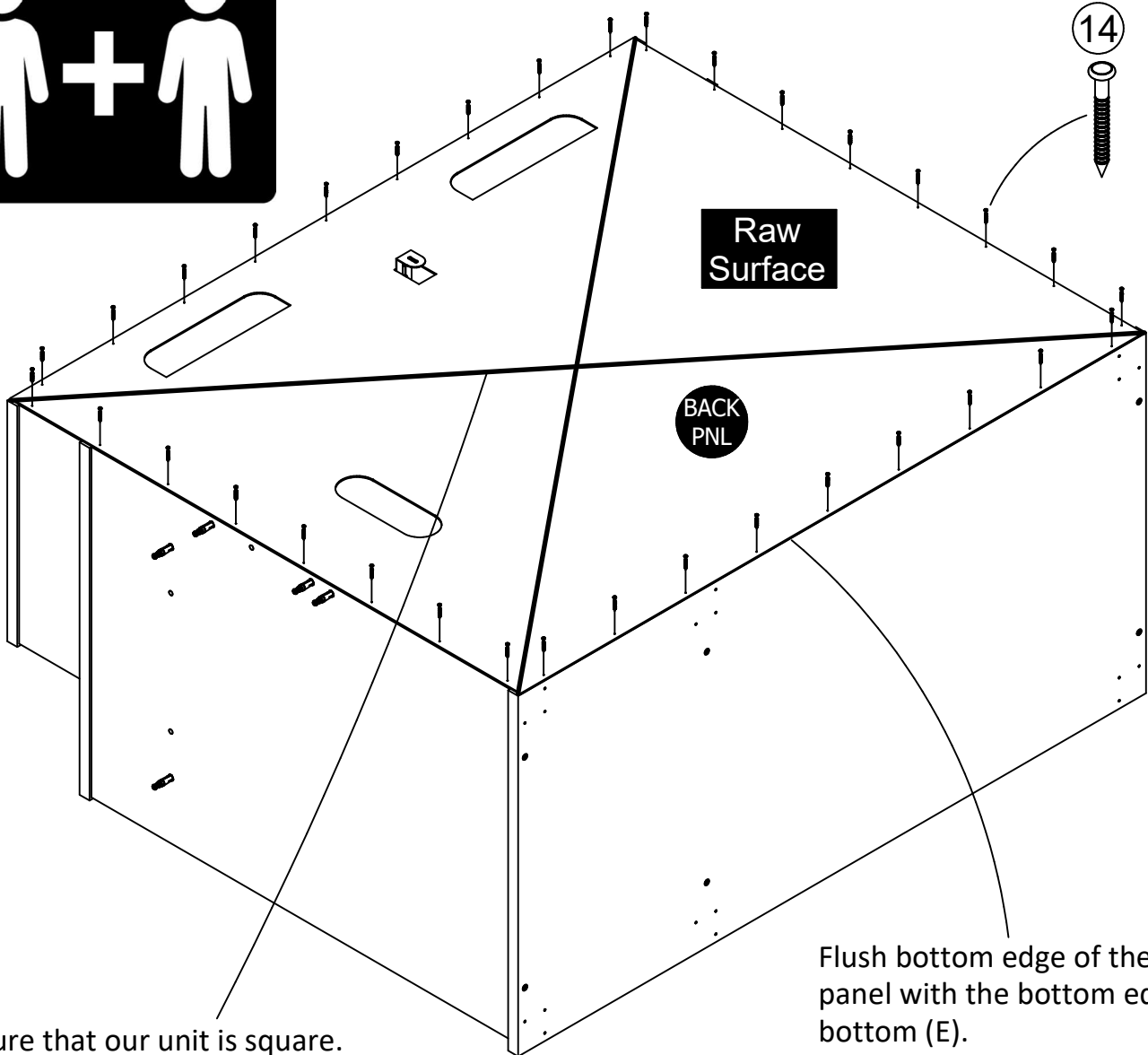
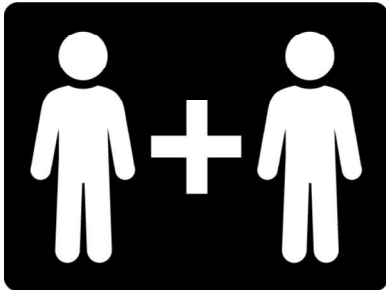

Assure that our unit is square.
Distance from corner to corner
must be equal as shown.

Flush bottom edge of the back
panel with the bottom edge of
bottom (E).

STEP 12

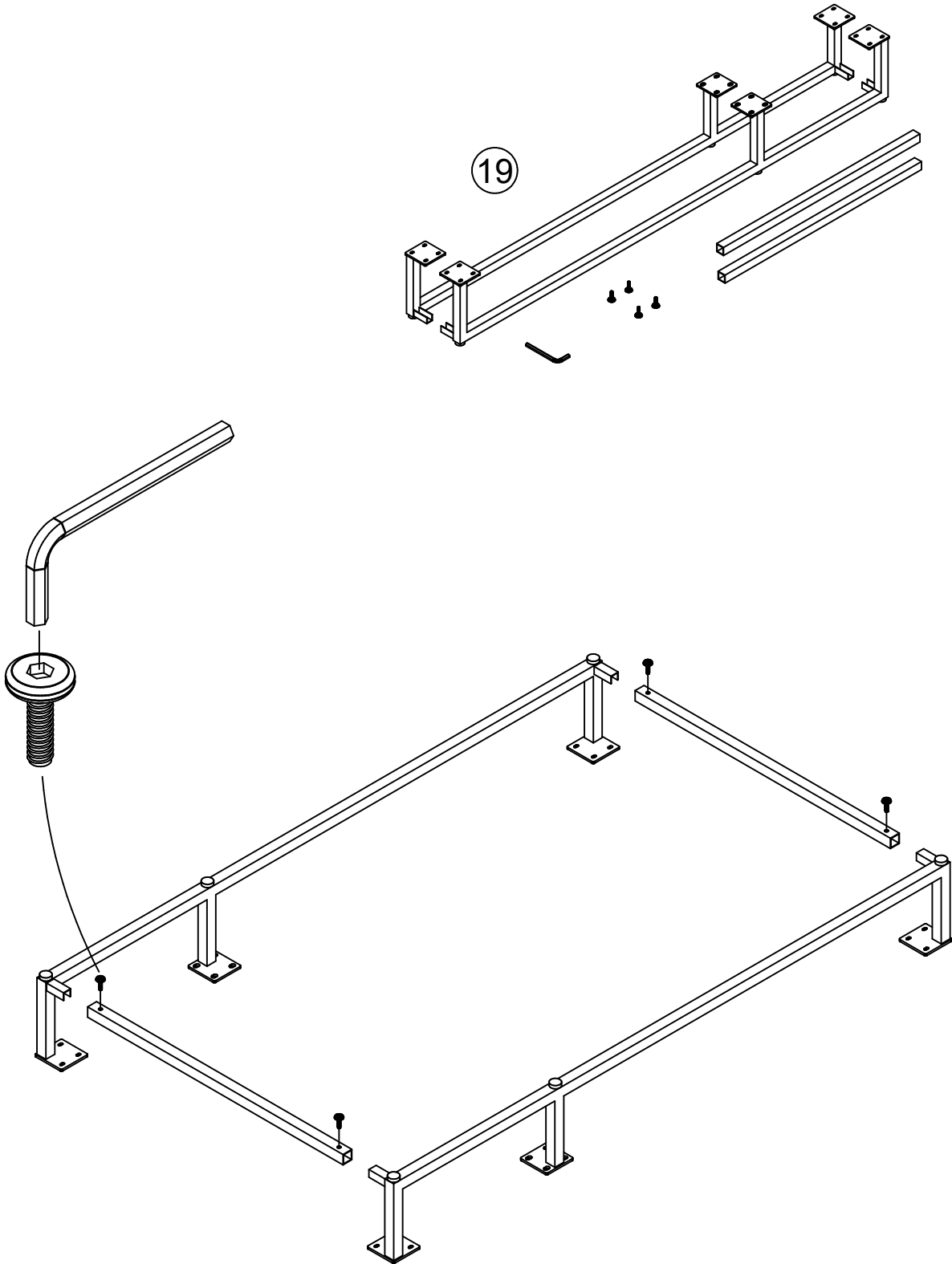

STEP 13

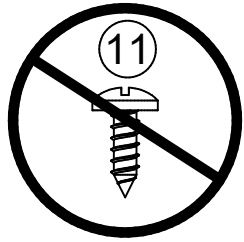
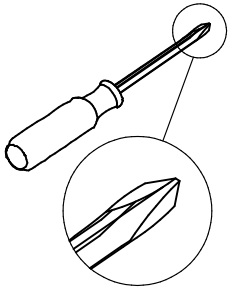

Do not get screws #8 and #11 mixed up. Screw #8 has a larger head and body.

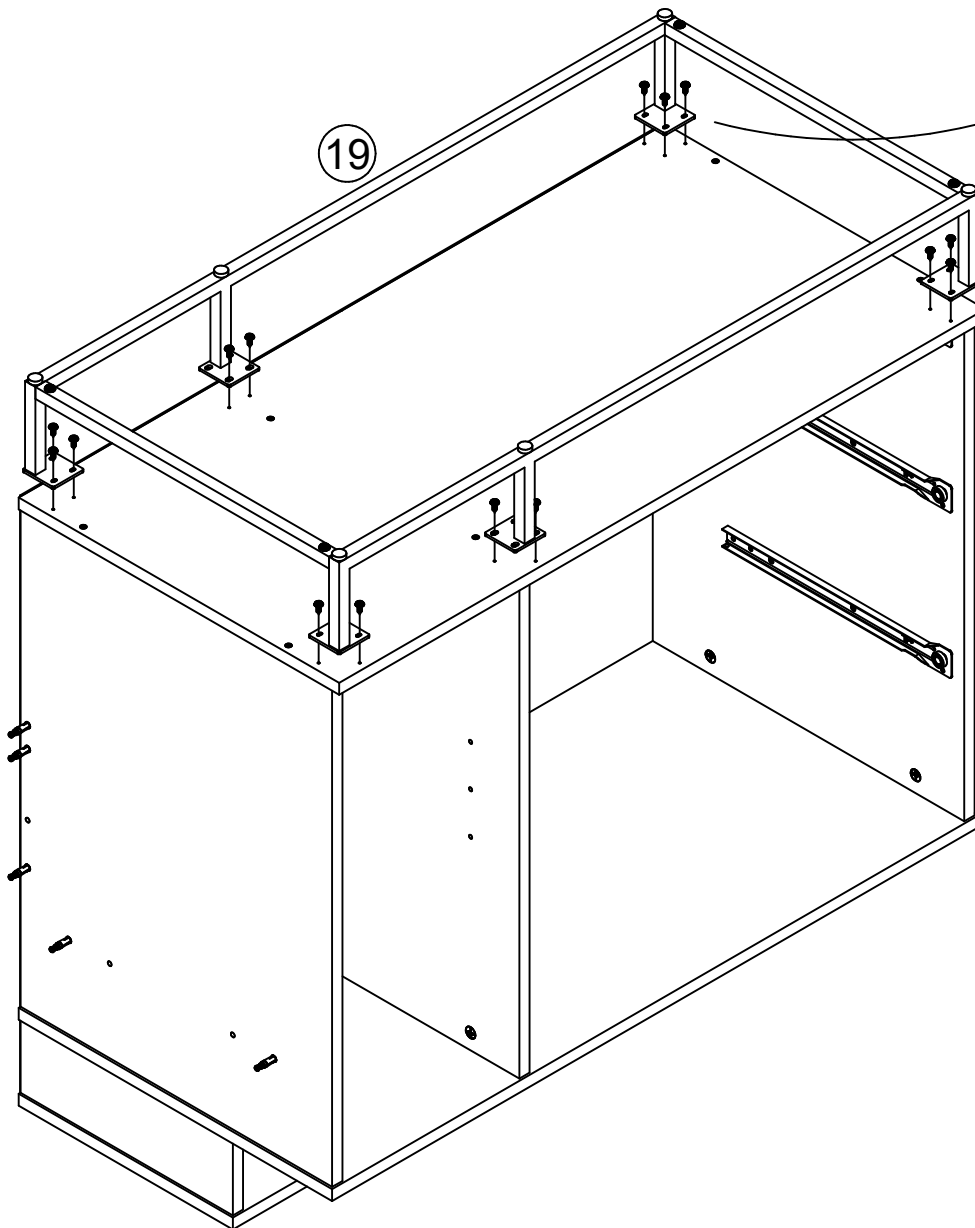
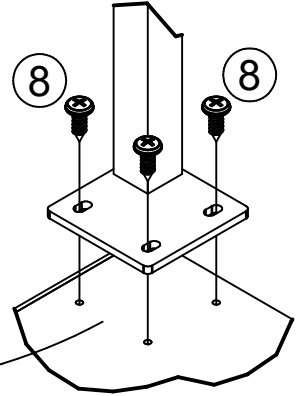

STEP 14

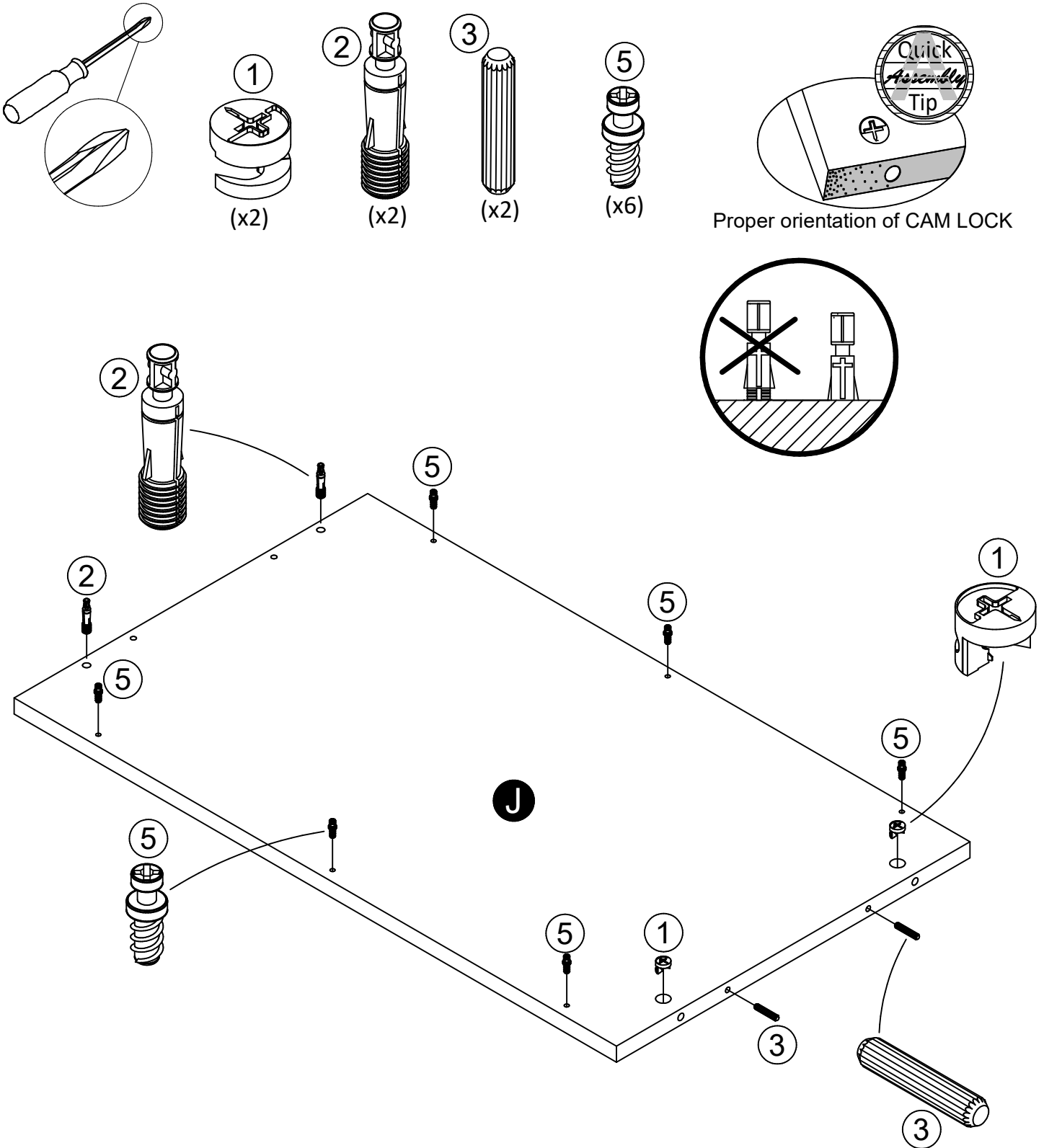

STEP 15

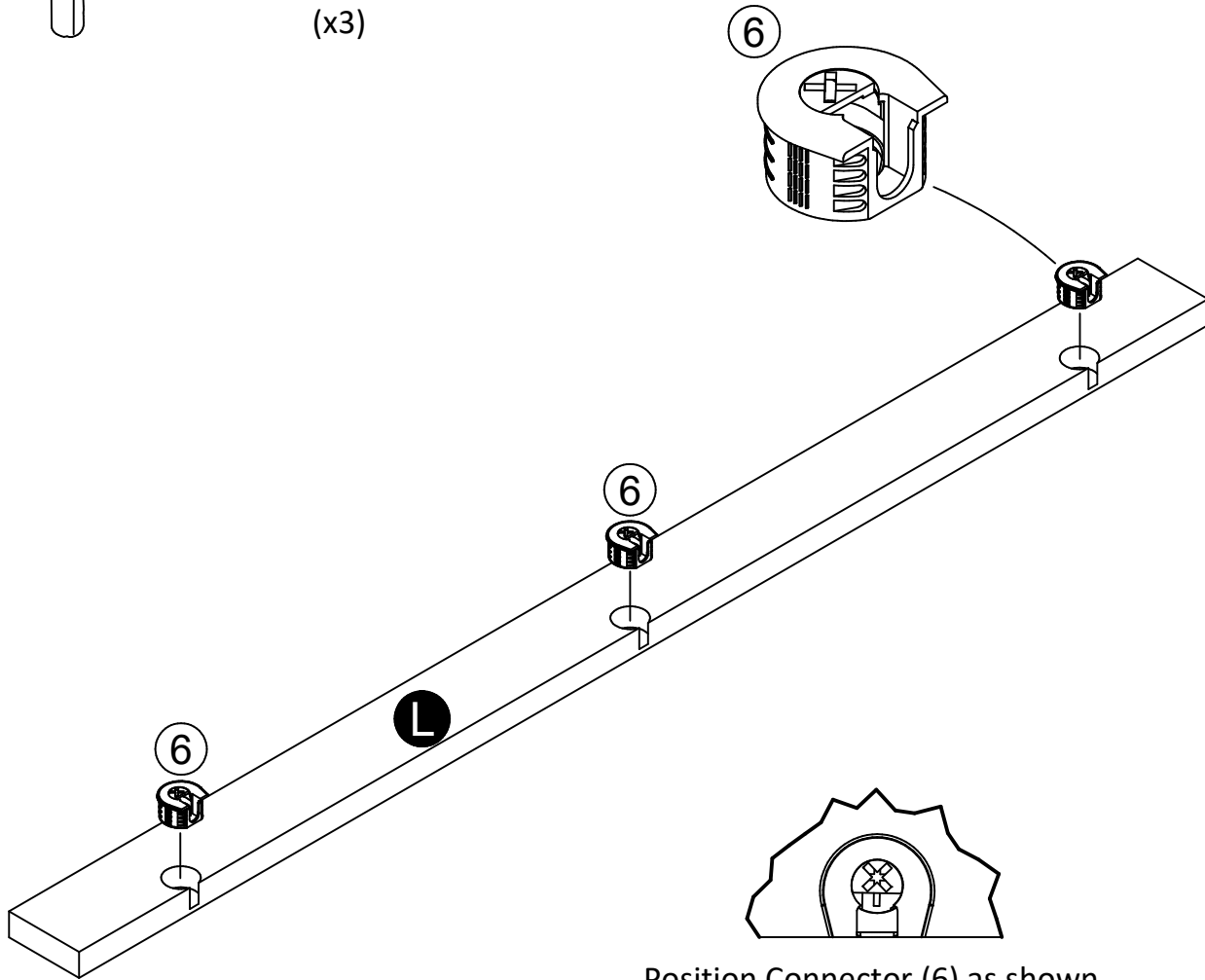
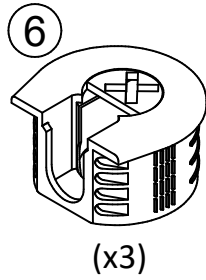
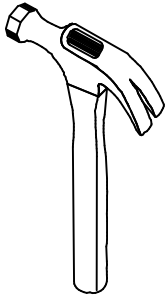

Position Connector (6) as shown
Tap Connector into hole using a hammer.

STEP 16

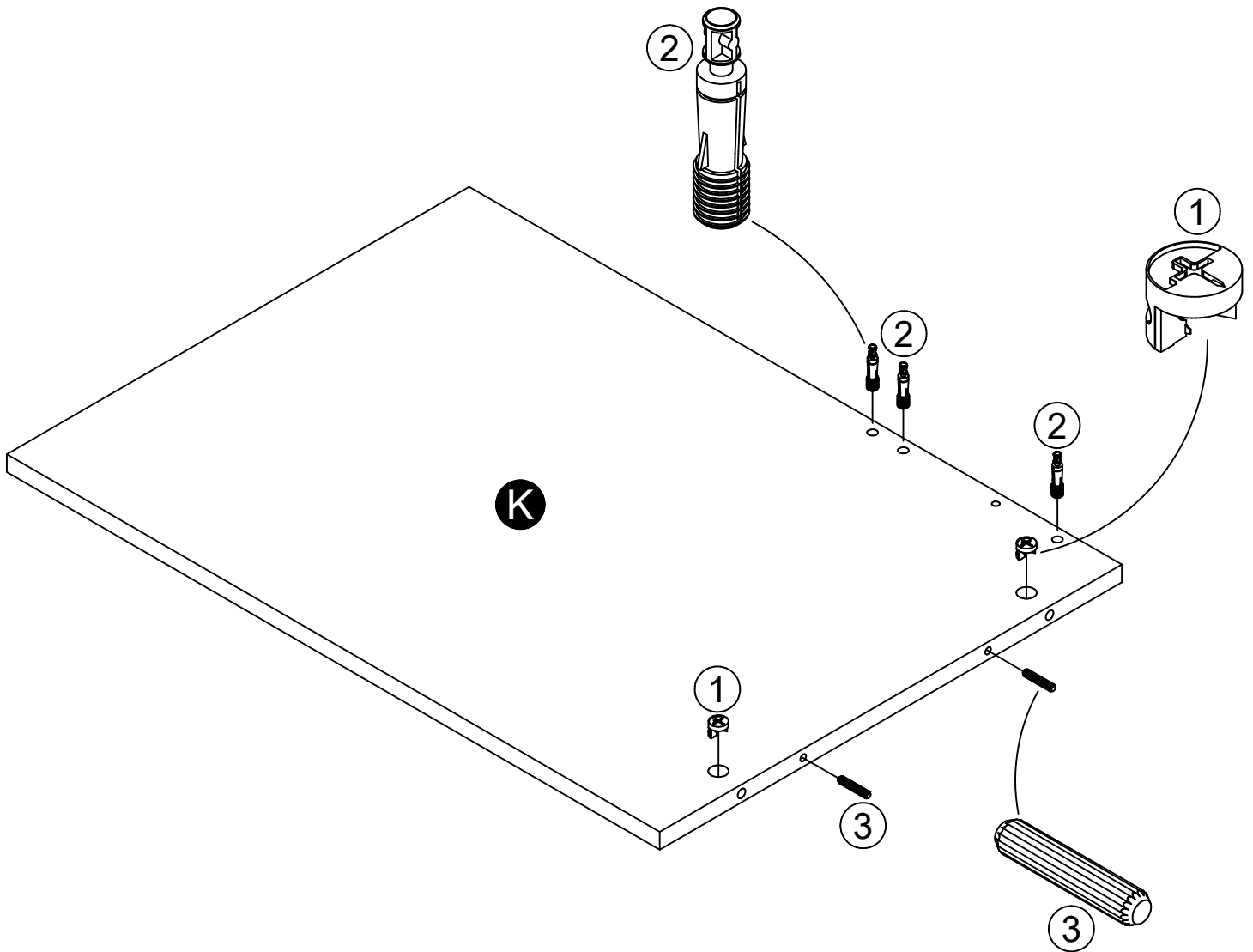
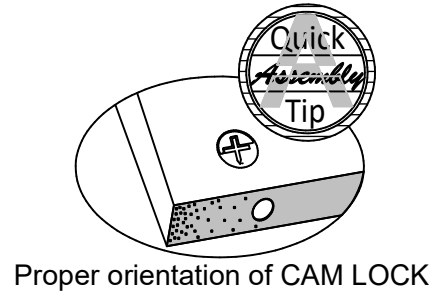
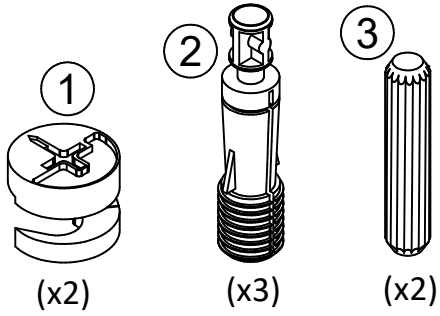

STEP 17

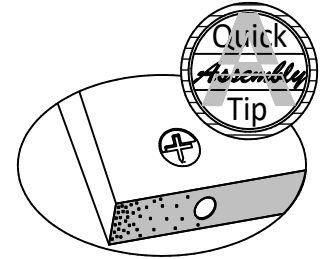
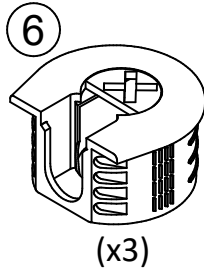
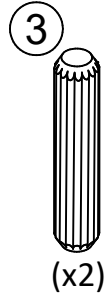
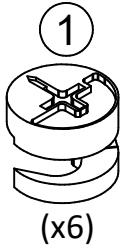
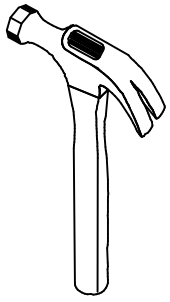

Proper orientation of CAM LOCK

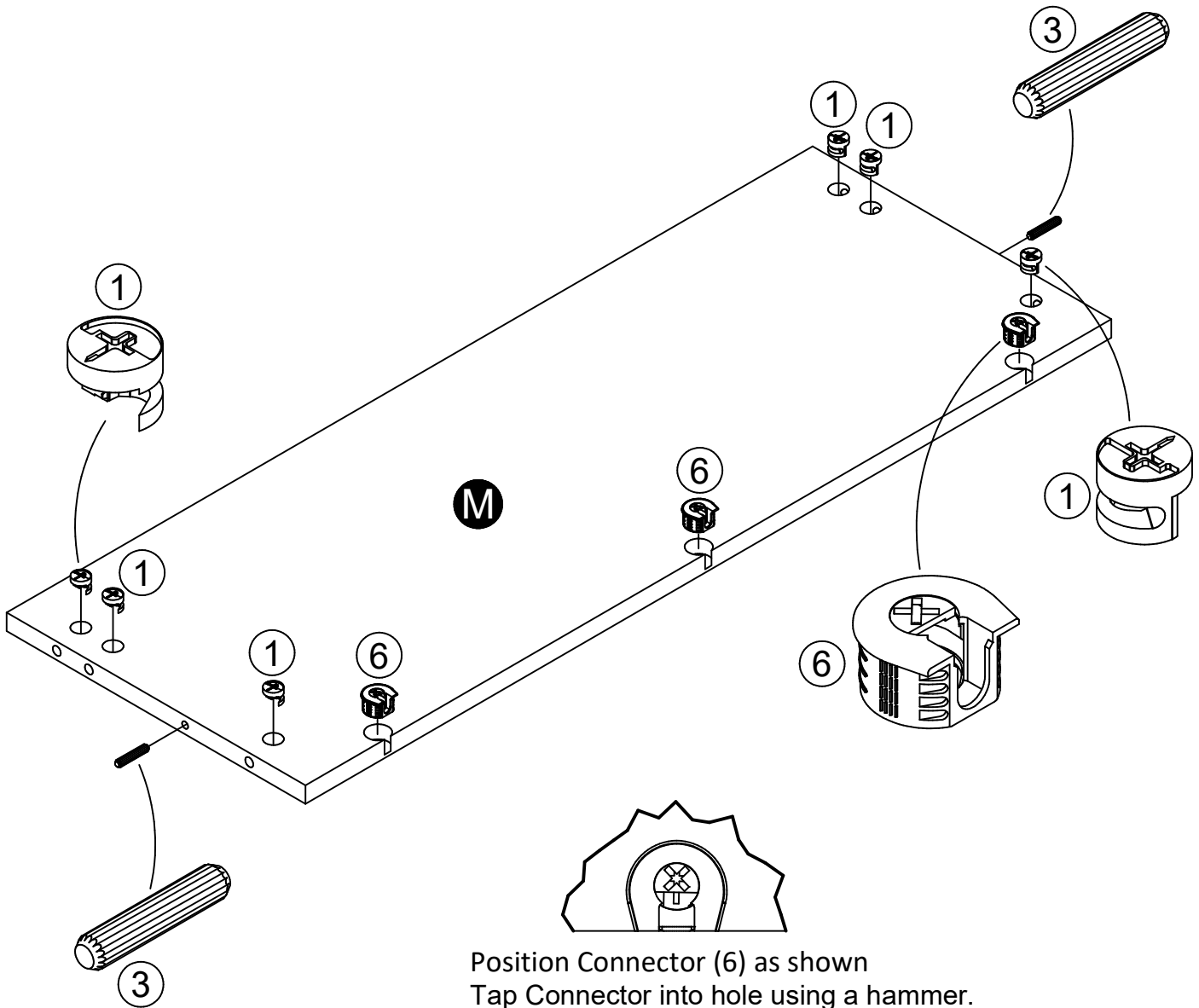

STEP 18

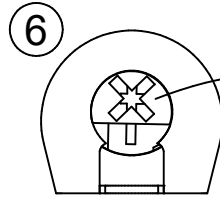
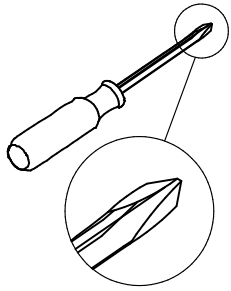

Turn screw clockwise to lock parts together.

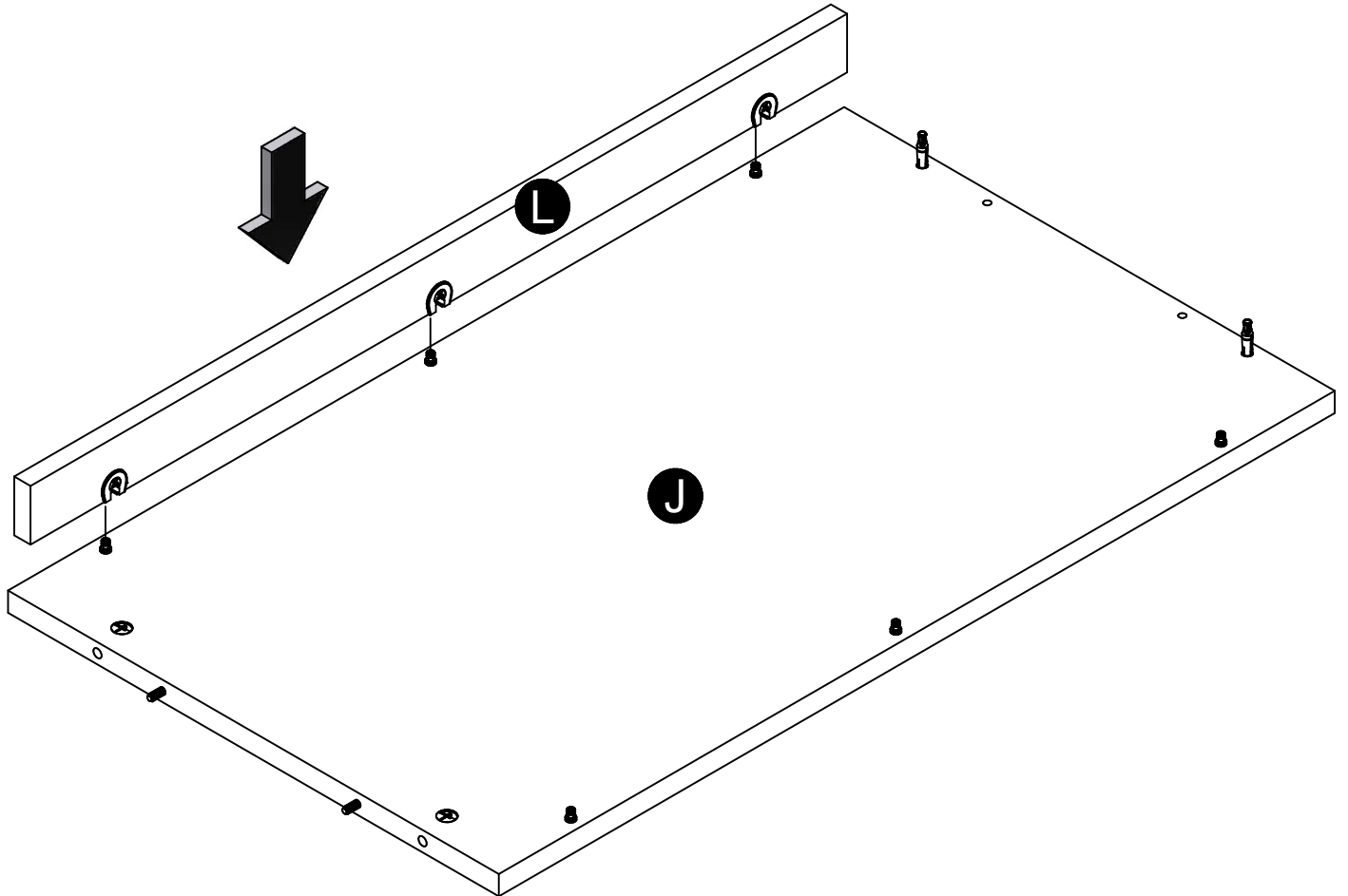

STEP 19

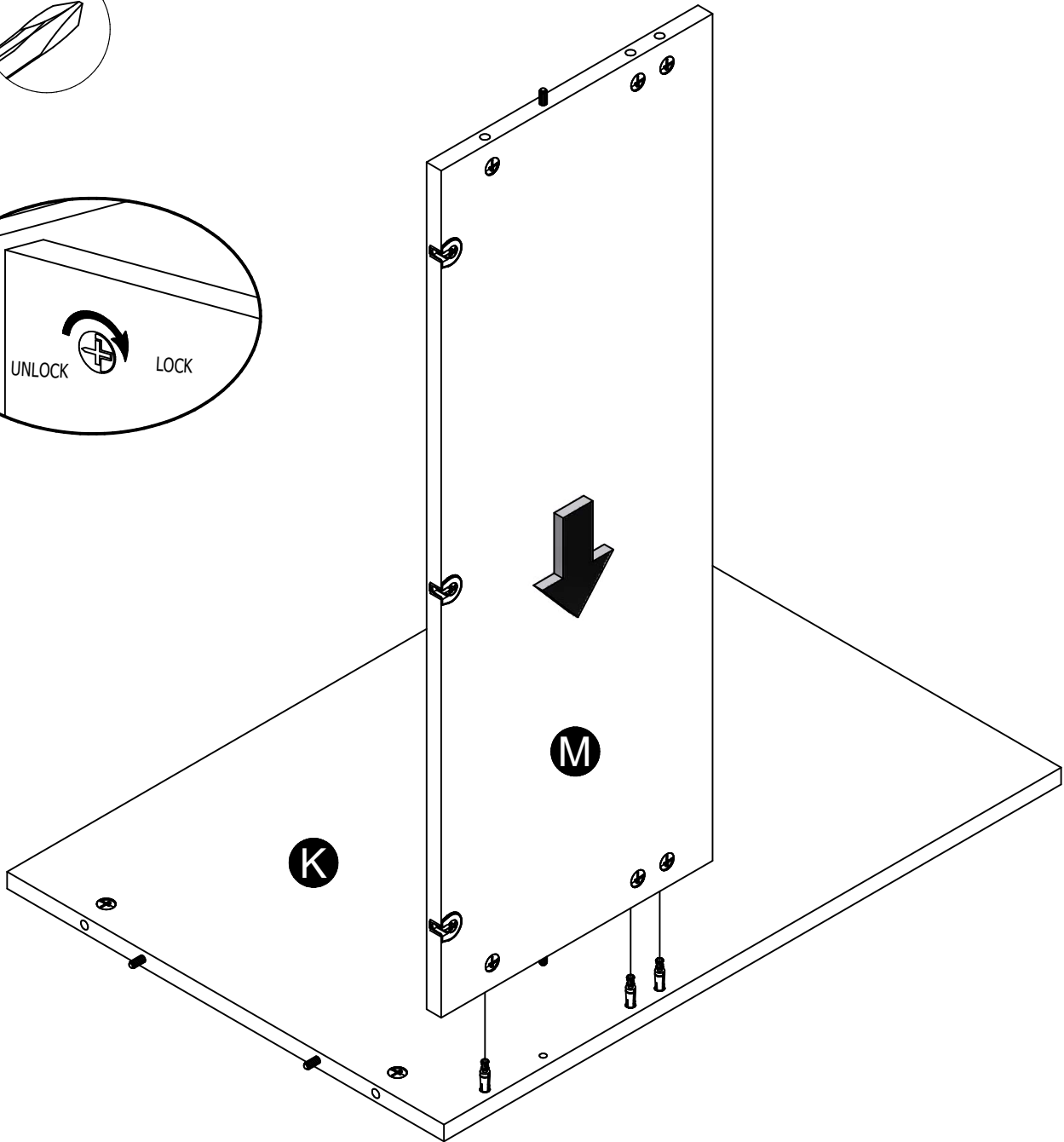
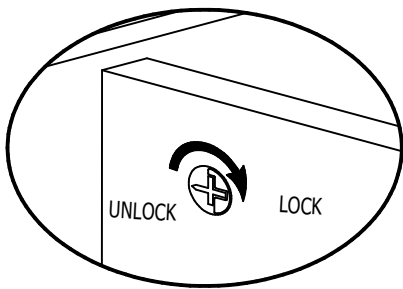
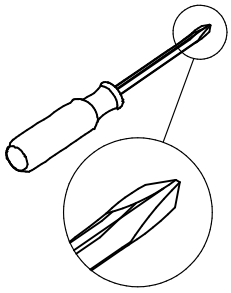

STEP 20

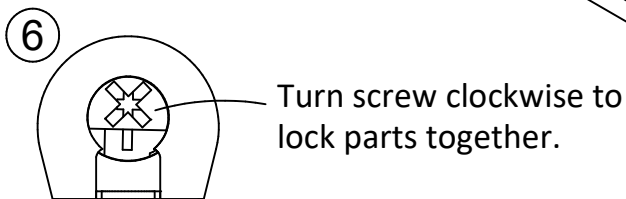
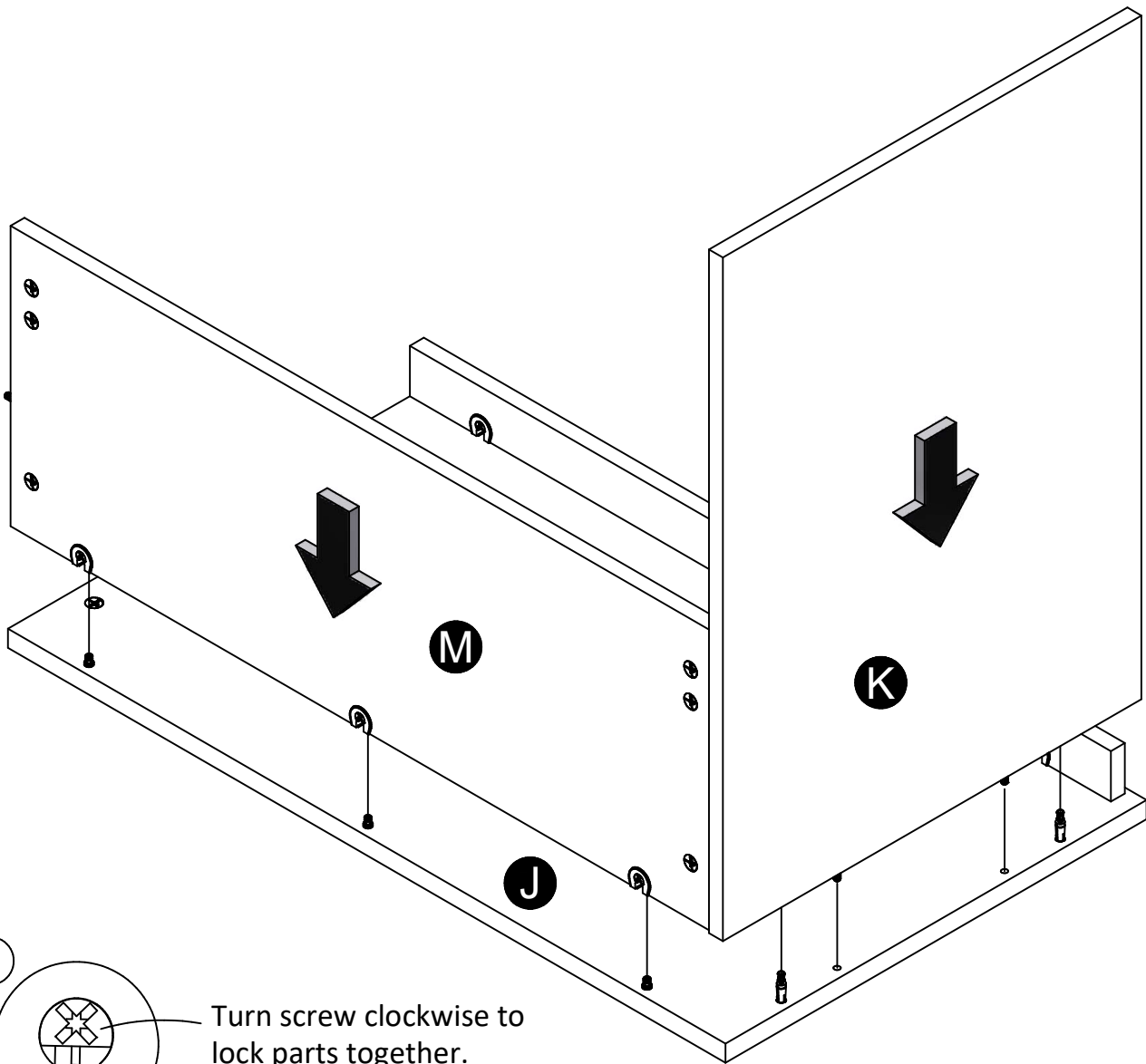
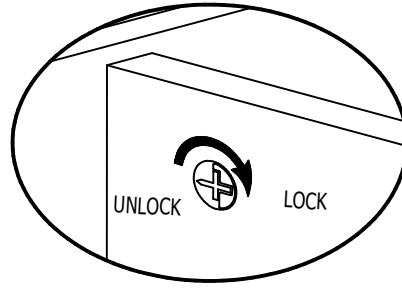
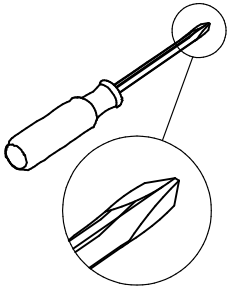

STEP 21

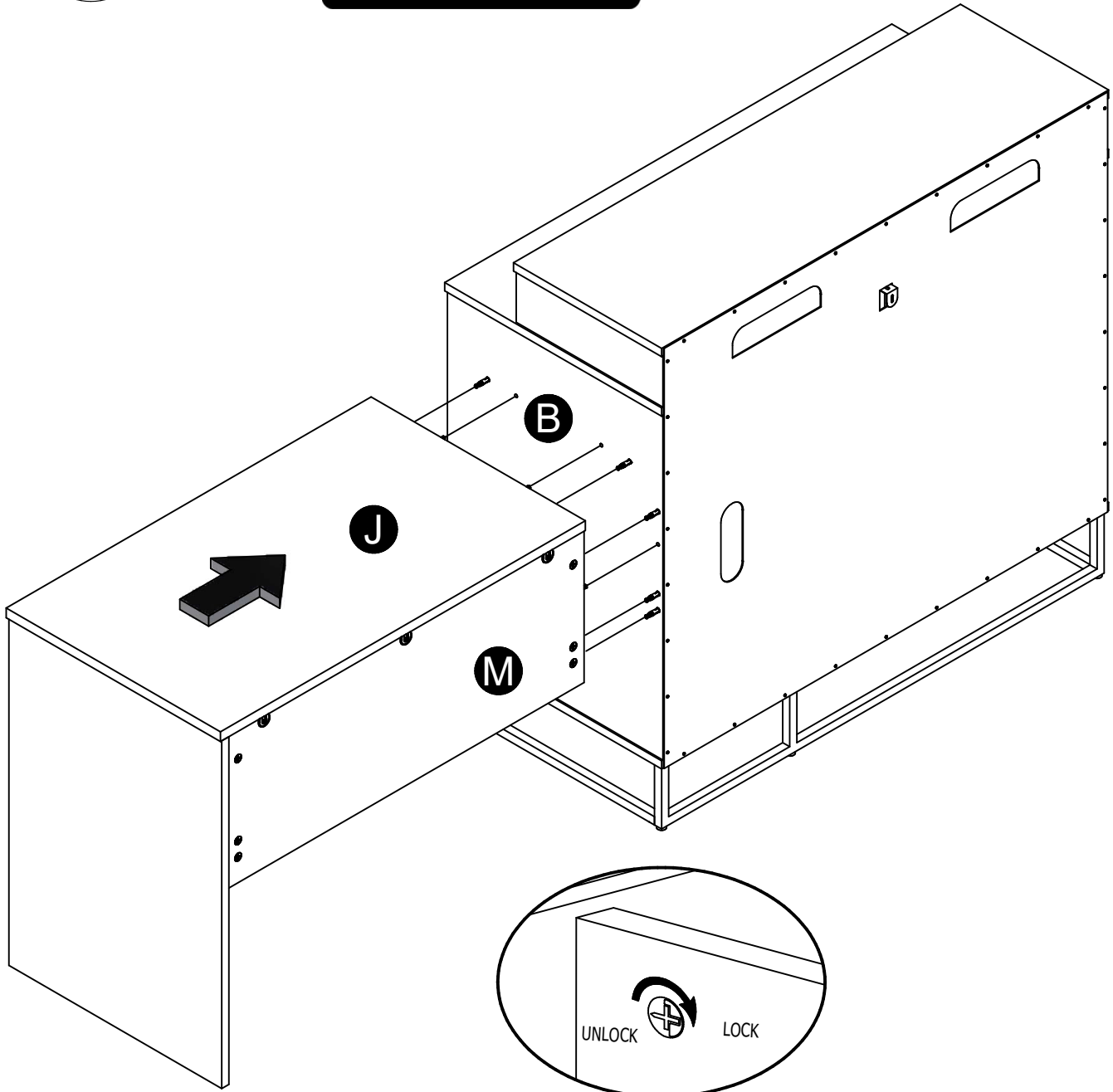
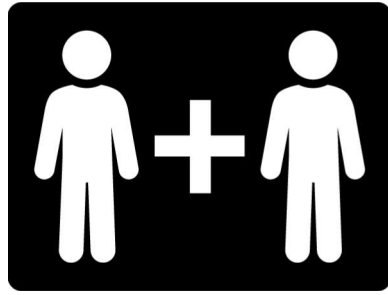
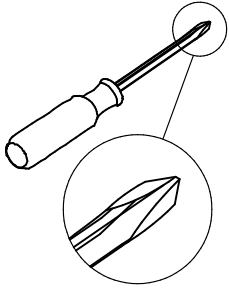

STEP 22

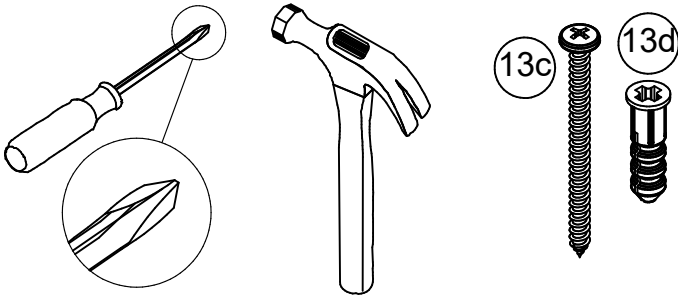

For Masonry, Concrete, or other wall materials:
Consult your local hardware store for appropriate anchors to securely attach the safety bracket.

IMPORTANT: THIS UNIT MUST BE SECURE TO THE WALL TO HELP PREVENT TIPOVER. FOLLOW THESE INSTRUCTIONS TO INSTALL THE ANTI-TIPPING SAFETY BRACKET PROVIDED WITH THIS PRODUCT.

WARNING
Serious or fatal crushing injuries can occur from furniture tipover.
To prevent tipover:

- * Install tipover restraint provided
- * Place heaviest items in the lowest drawers
- * Unless specifically designed to accommodate, do not set TVs or other heavy objects on the top of this product
- * Never allow children to climb or hang on drawers, door, or shelves
- * Never open more than one drawer at a time

Use of tipover restraints may only reduce, but not eliminate the risk of tipover

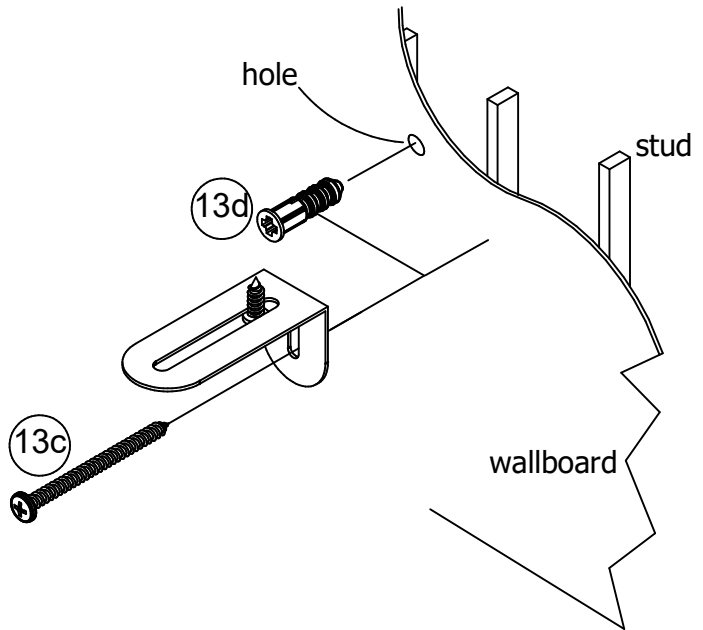

OPTION 1: Attachment into a wall stud (preferred method)

Using a stud finder, locate a stud in the wall. Place your unit against the wall, with the safety bracket aligned in this location. To make driving the screw easier, you can drill a 1/8" diameter pilot hole (3mm) through the safety bracket into the stud. Drive the screw through the safety bracket into the wall stud. Tighten the screw that was not fully tightened in step 9.

OPTION 2: Attachment into drywall

Locate your unit where desired against a wall and mark the wall through the safety bracket, then move your unit aside. Drill a 3/16" diameter hole (5mm) into the wallboard. Tap the wall anchor into the hole until it is flush. Move your unit into location and fasten the wall bracket to the wall anchor with the screw. Tighten the screw that was not fully tightened in step 9.

STEP 23

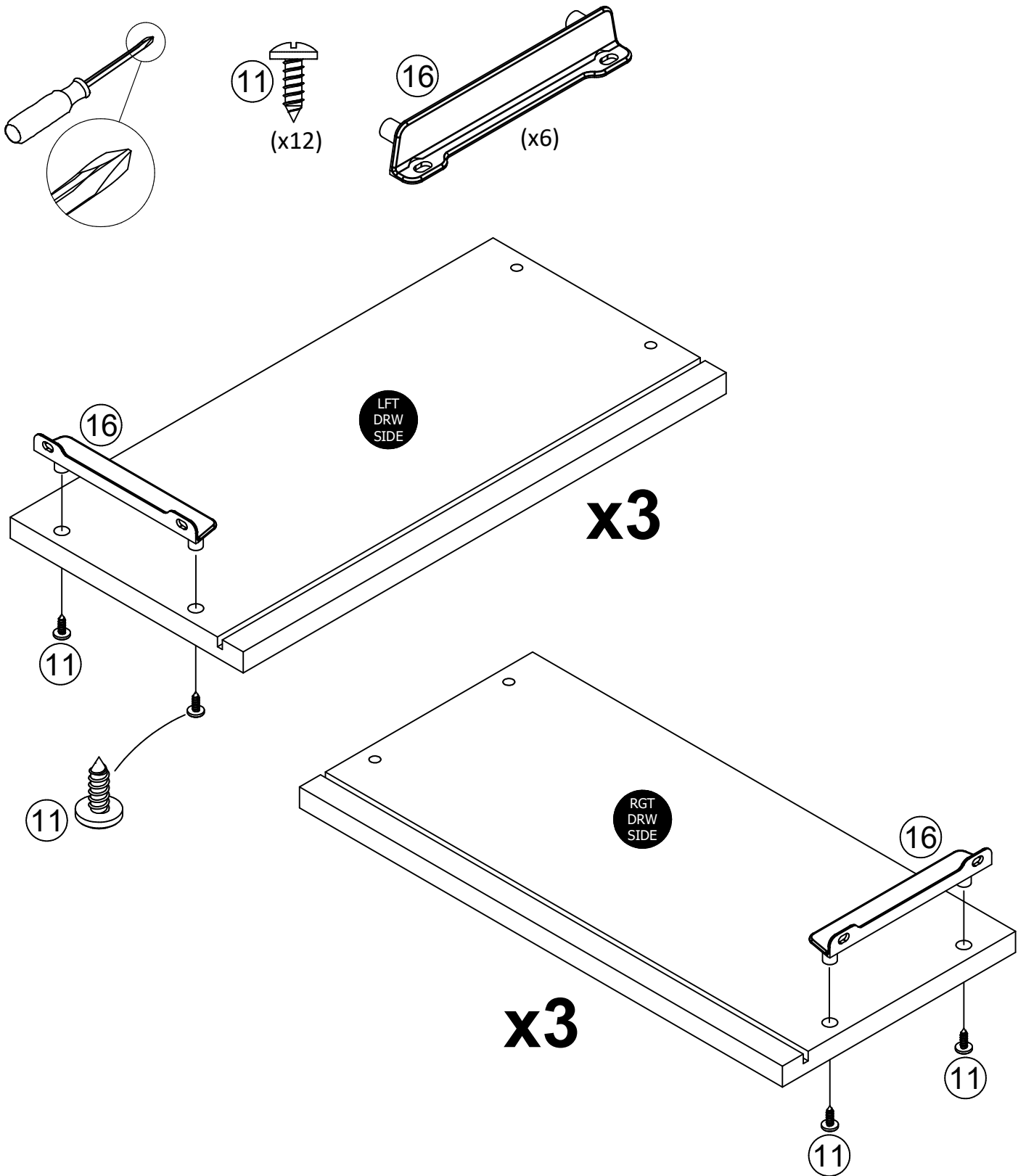

STEP 24

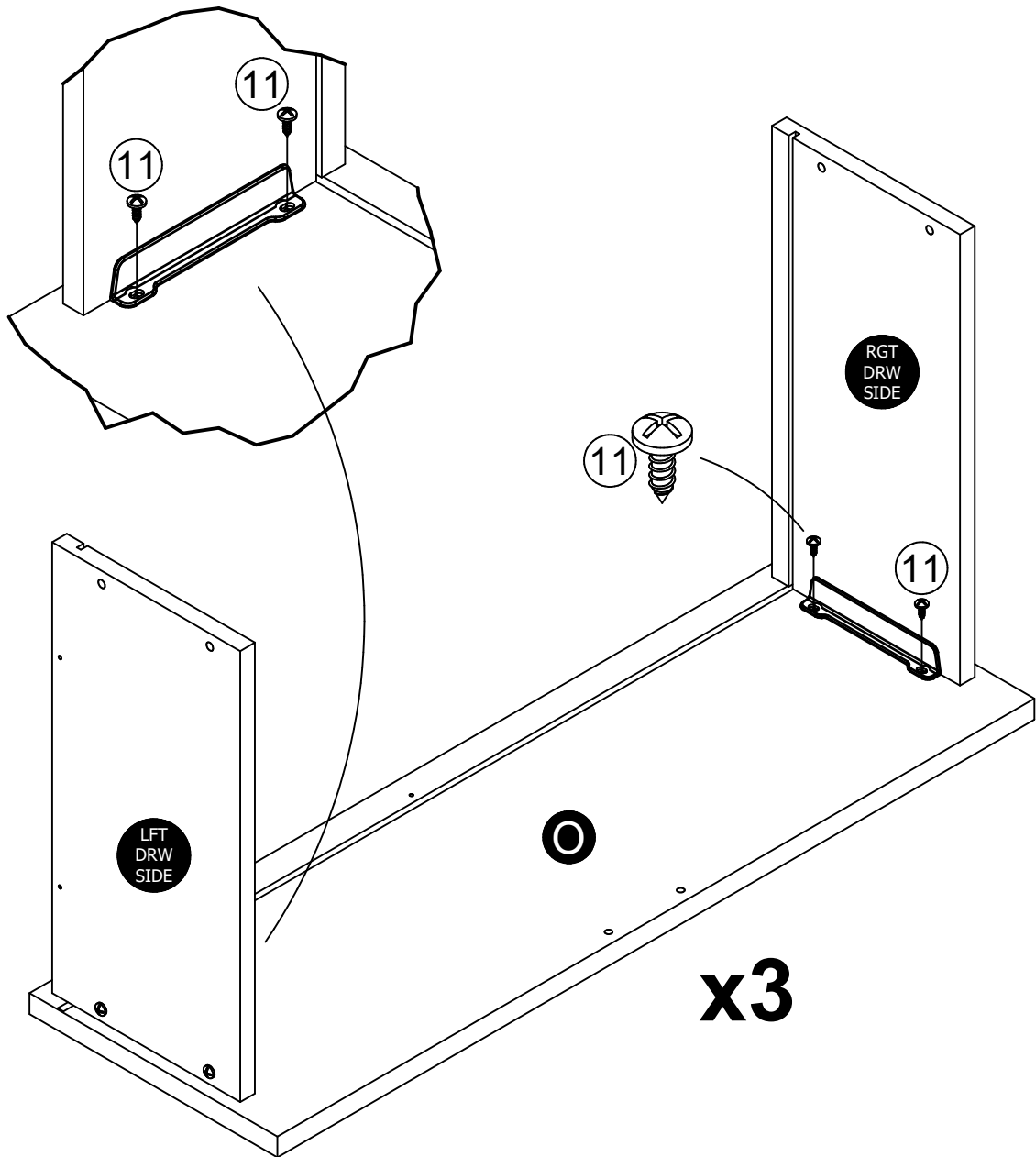
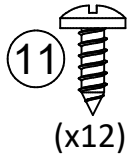
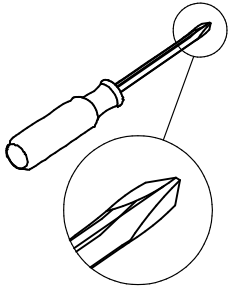

STEP 25

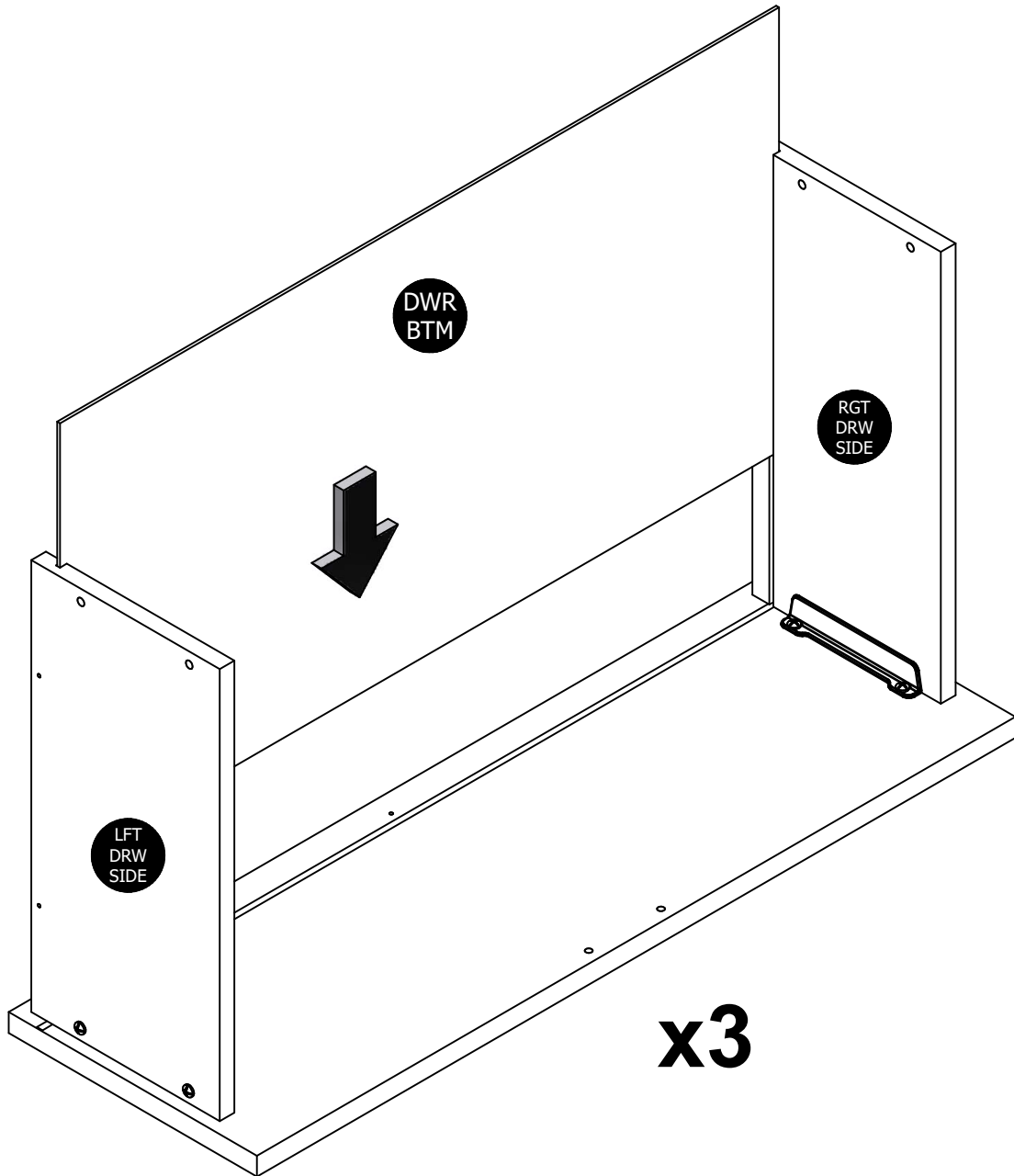

STEP 26

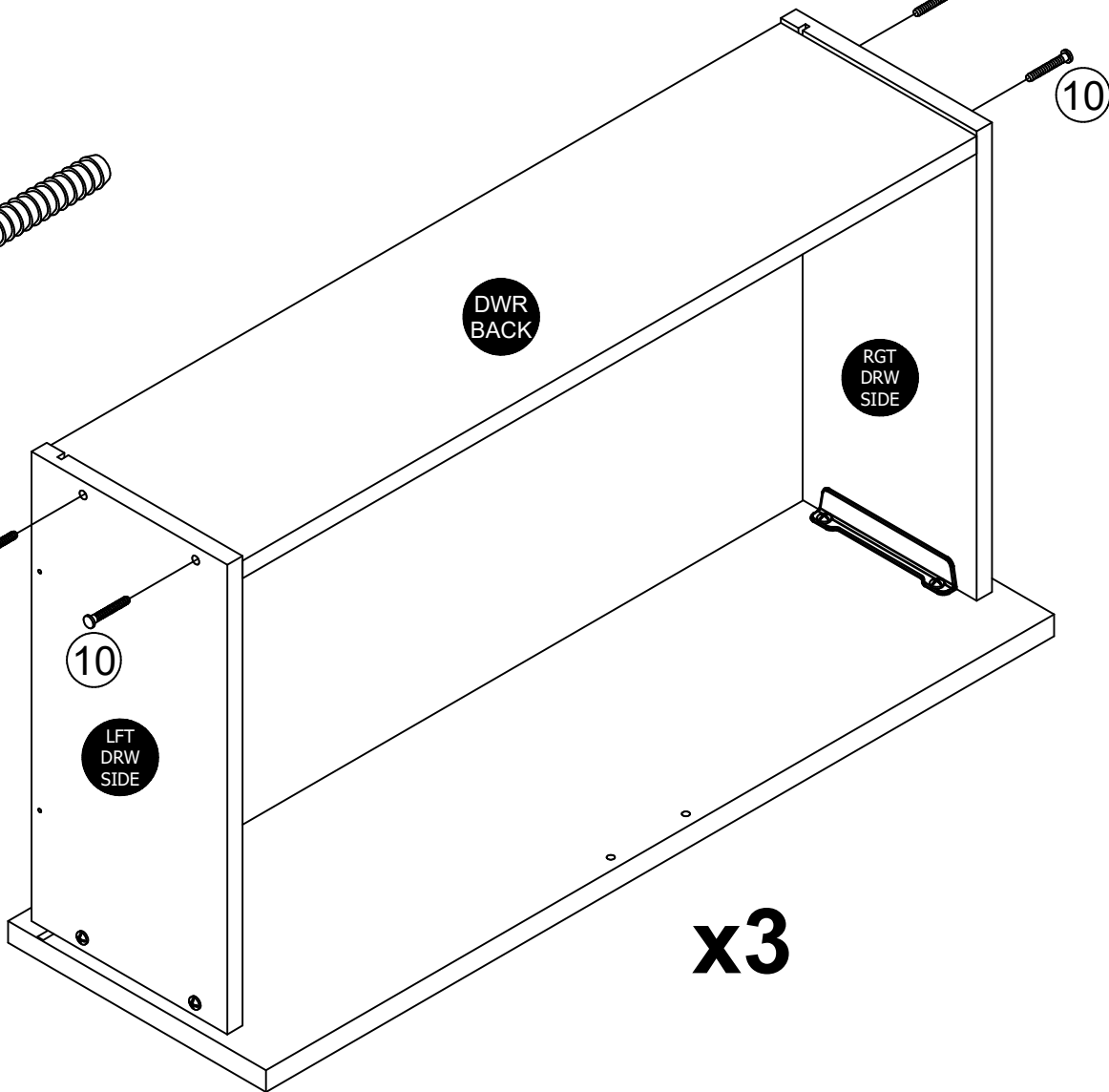
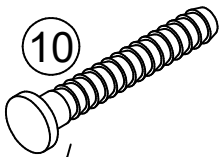
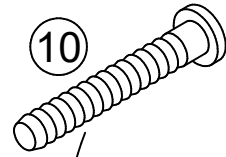
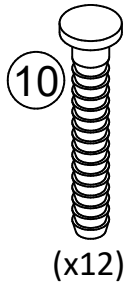
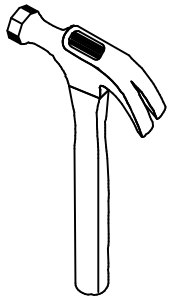

STEP 27

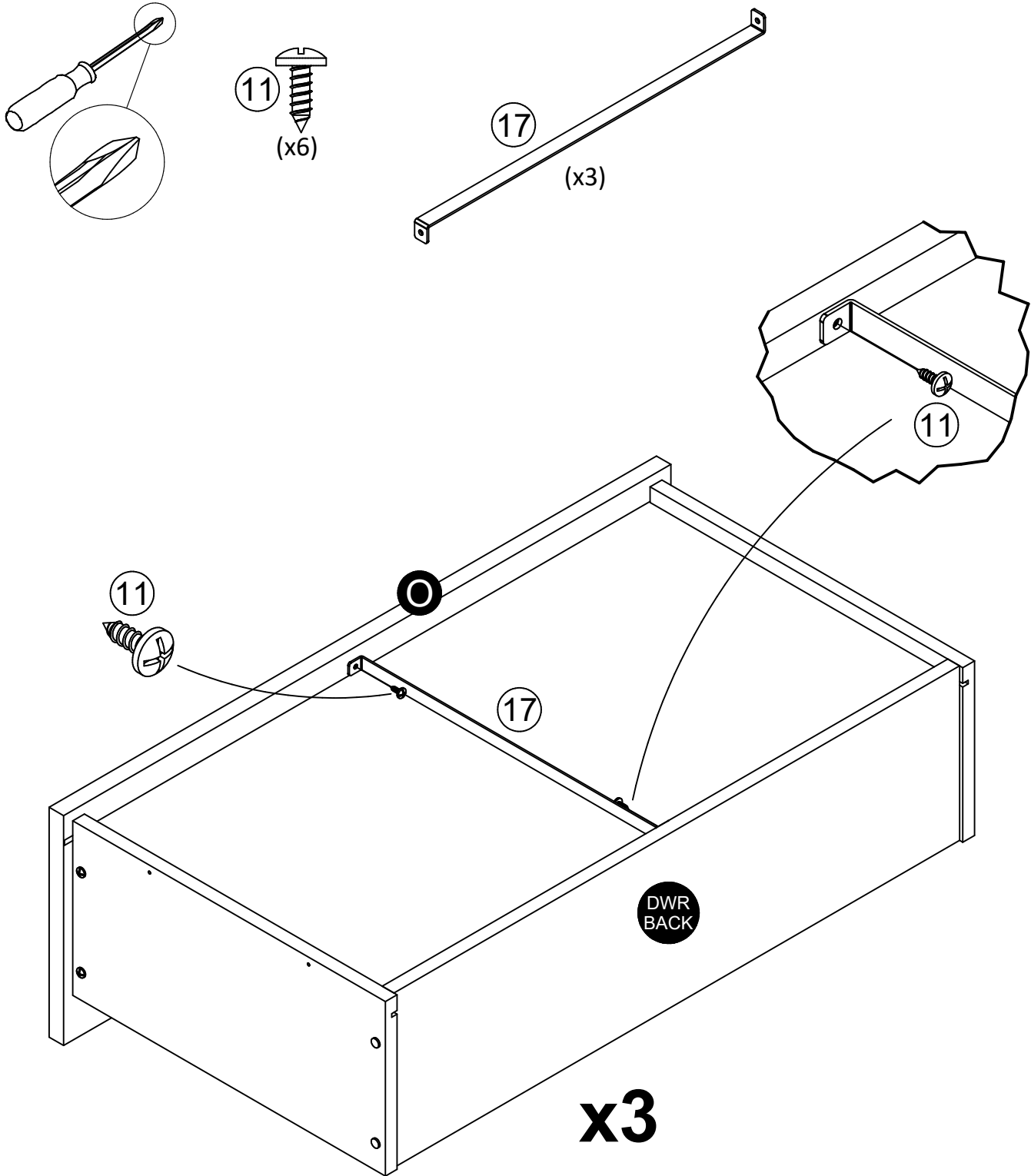

STEP 28

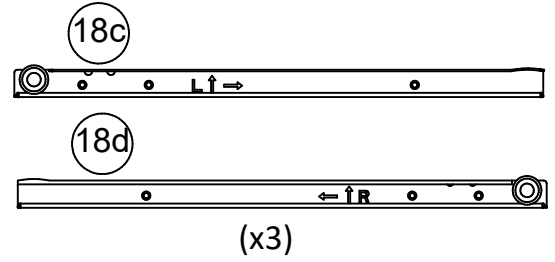
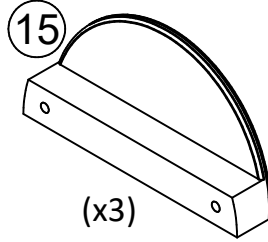
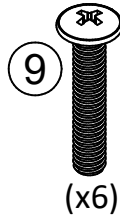
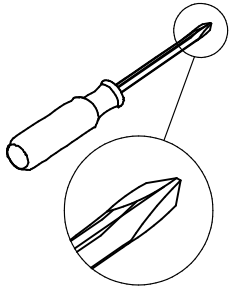

Attach the slides first and then the handle.

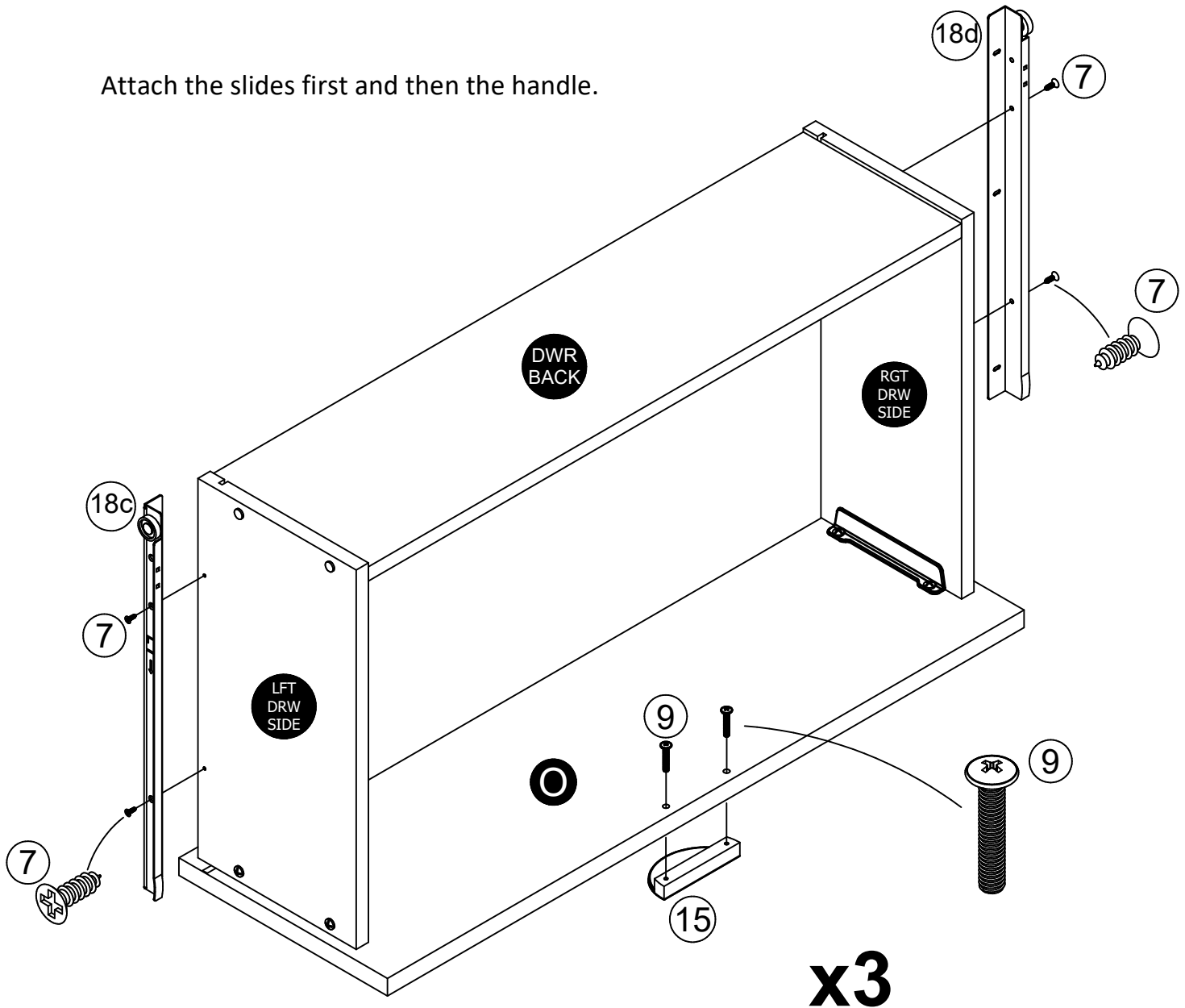

STEP 29

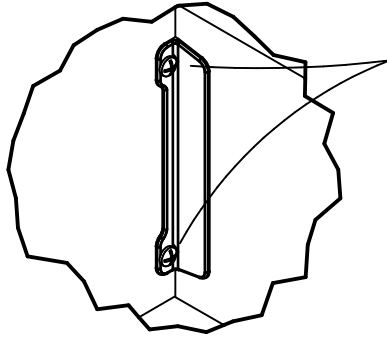

Note: The drawer bracket holes are slotted. Drawer fronts can be adjusted by loosening screws, making needed adjustments and retightening screws.

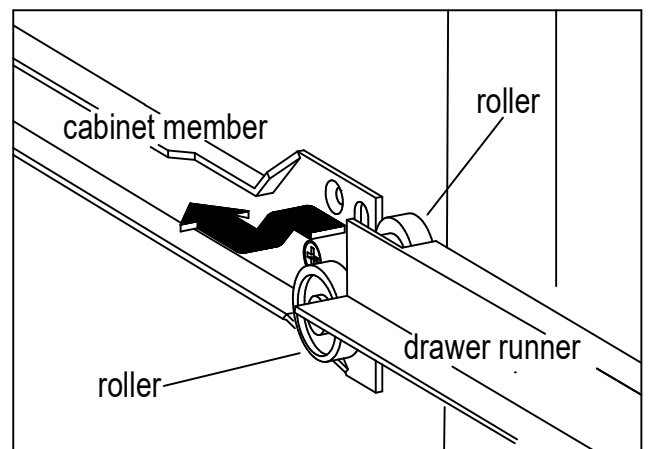
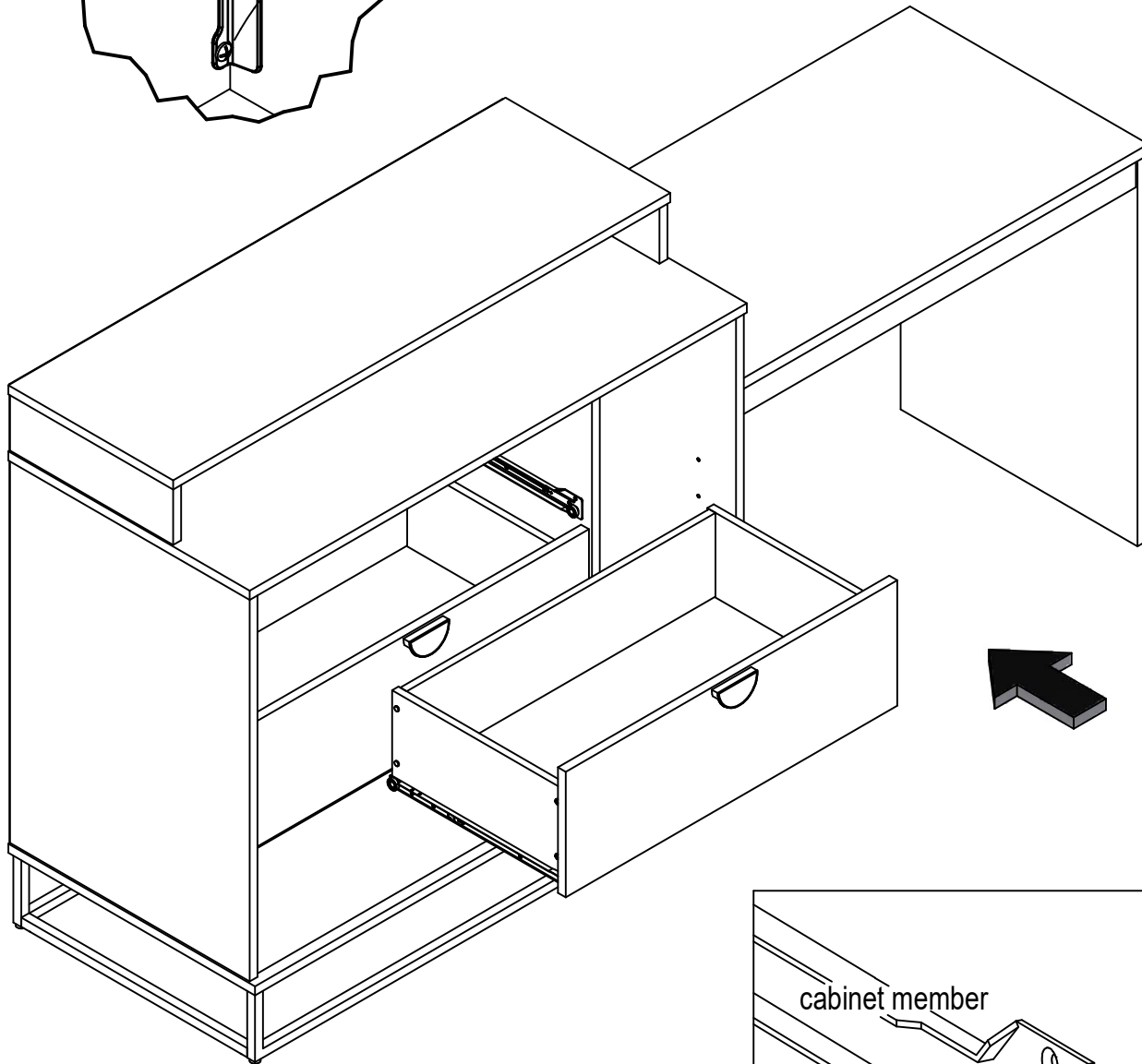

STEP 30

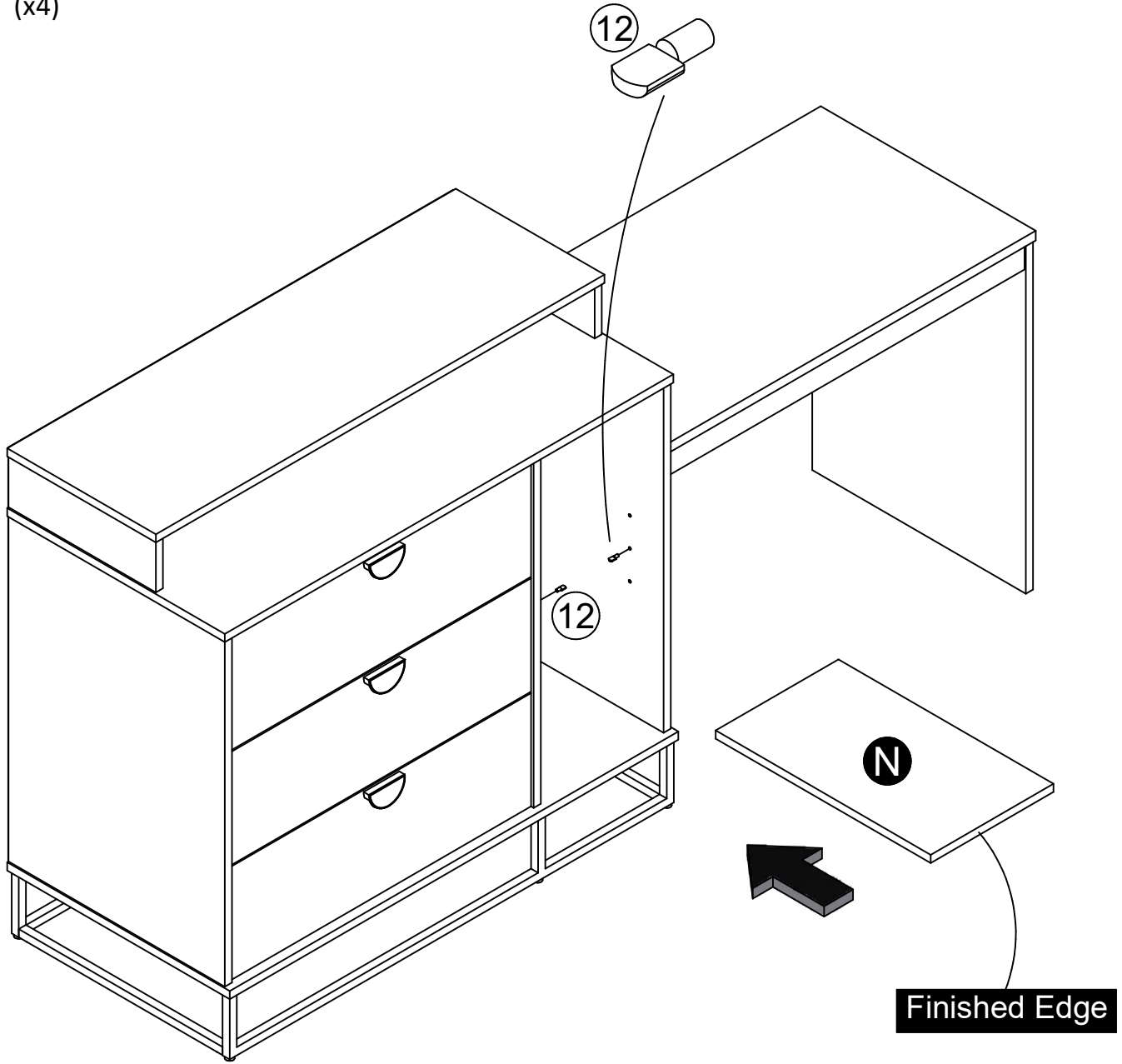
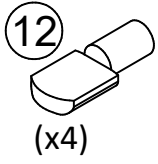

Maximum Loads

This unit has been designed to support the maximum loads shown. Exceeding these load limits could cause sagging, instability, product collapse, and/or serious injury.

⚠ WARNING
 Never use this Furniture with a TV that is too large or too heavy. Serious injury or death can occur. The TV and furniture can be unstable and may tip.
 • The TV must weigh less than 40 lbs. (18.1 kg)
 • The base of the TV must be able to sit completely on this surface.
 NO CRT (TUBE TYPE) TV PERMITTED. This item is designed for most FLAT PANEL TV's having up to a 39" (99.1 cm) diagonal screen measurement. Refer to instruction book for complete safety information.

⚠ AVERTISSEMENT
 Ne jamais utiliser ce mobilier avec un téléviseur trop grand ou trop lourd. Des blessures graves ou la mort peuvent survenir. Le téléviseur et le meuble peuvent devenir instables et renverser.
 • Le téléviseur doit peser moins de 18.1 kg (40 lb.)
 • La base du téléviseur doit être capable de reposer complètement sur cette surface.
 AUCUN TÉLÉVISEUR TUBE (TYPE TUBE) PERMIS. Ce produit est conçu pour le plupart des TÉLÉVISEURS À ÉCRAN PLAT avec un écran mesurant 99.1 cm (39 po) diagonalement. Veuillez vous reporter au manuel d'instruction pour de l'information complète sur le sécurité.

B64339

Apply TV warning label to your unit for future reference.
 Notice: Once you apply this label to your unit, you cannot remove it.

Maximum TV (flat screen) 39"

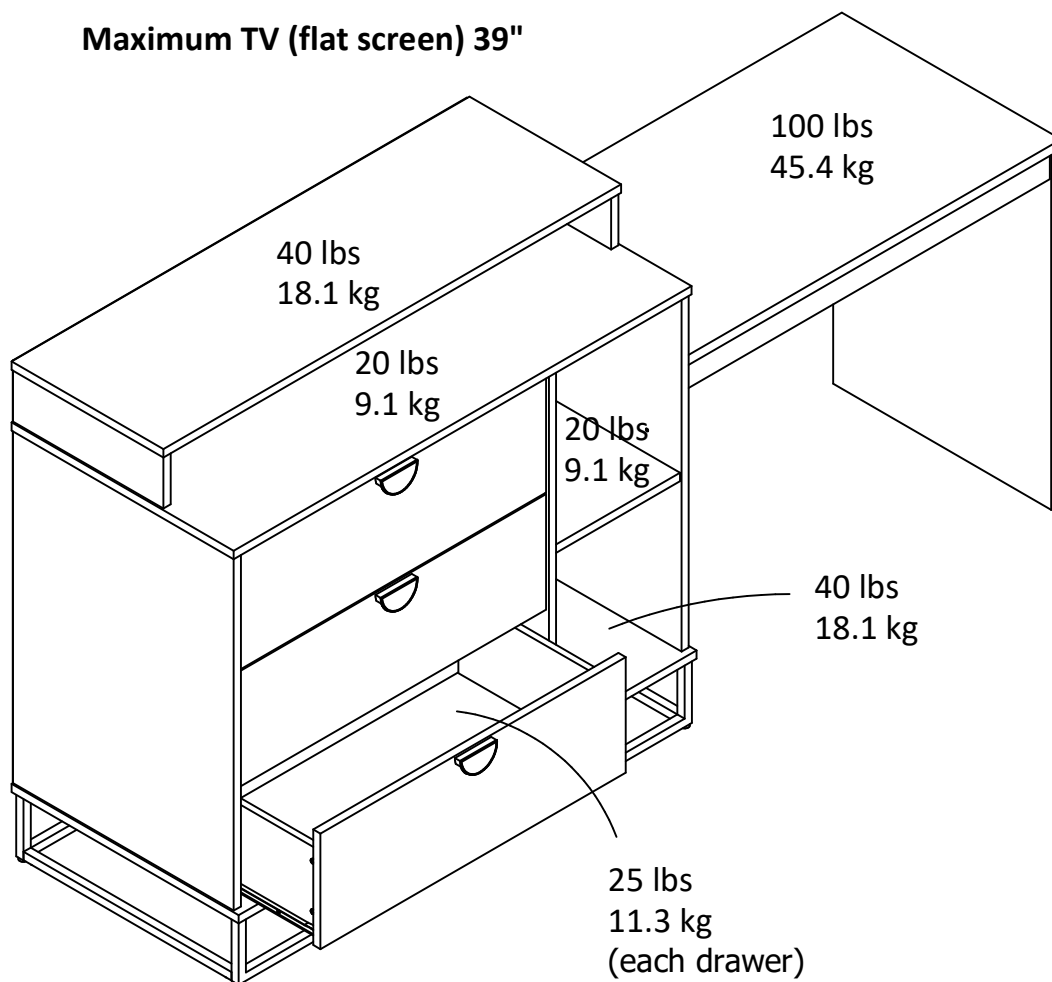

B64339
 TV Warning Label

Certificate of Conformity

1. This certificate applies to the Dorel Home Furnishings, Inc. product identified by this instruction manual.
2. This certificate applies to compliance of this product with the CPSC Ban on Lead-Containing Paint (16 CFR 1303).
3. This product is distributed by: Dorel Home Furnishings, Inc.

410 East First Street South
 Wright City, MO 63390
 636-745-3351

4. Site of Manufacture: Tiffin OH
5. See front page of instruction manual for date of manufacture.

Register your product to receive the following:



- * New trend details - sneak peek on what's new
- * Surveys - have a voice within our community
- * Exclusive deals and discount codes
- * Quick and easy replacement part service

To register your product, visit ameriwoodhome.com

5 Star Rating



Visit your local retailer's website, rate your purchased product and leave us some feedback!

We would like to extend a big "Thank You" to all of our customers for taking the time to assemble this Ameriwood Home product, and to give us your valuable feedback.

*Thank
You!*

Español

Cubierta Delantera

Este libro de instrucciones contiene información **IMPORTANTE** de seguridad. Por favor lea y manténgalo para referencia en el futuro.

No Regrese este producto! Comuníquese con nuestro amigoso equipo de servicio al cliente para obtener ayuda.

Llámenos al: 1-800-489-3351 (Gratis) Lunes - Viernes 9am - 5pm CST

Visitar: www.ameriwoodhome.com

PRECAUCION

Este mueble puede volcarse y causar graves heridas y/o muerte.

Anclar el mueble a un poste de madera en la pared (si esto se requiere).

No Permita que los niños monten el mueble.

Mantenga los artículos más pesados en los cajones de abajo.

Consejos Útiles (página 2)

- Abra su artículo en el área donde usted planea utilizarlo para evitar levantar y moverlo menos
- Identificar, ordenar y contar las piezas antes de intentar ensamblar
- Las clavijas de compresión se golpean con un martillo
- Las diapositivas están marcadas con una R (derecha) y L (izquierda) para la colocación correcta
- Asegúrese de que siempre este el punto localizado en la parte superior de bloqueador de leva este volteado hacia borde exterior
- Utilizar todos los clavos para el panel de atrás y distribuirlos por igual
- El panel de atrás debe utilizarse para asegurarse de que la unidad quede fija y firme
- No use químicas fuertes ni limpiadores abrasivos en este artículo
- Nunca empuje, tire ni arrastre los muebles

Antes de Que Empieces (página 3)

- Lea cuidadosamente cada paso y siga el orden correcto
- Separar y contar todas sus piezas y hardware
- Dése suficiente espacio para el proceso de ensamble
- Tenga las siguientes herramientas: destornillador de cabeza plana, #2 cabeza Phillips
Destornillador y martillo
- Precaución: Si usa un taladro electrónico o un destornillador eléctrico para atornillar, por favor asegúrese que deje de atornillar cuando el tornillo este apretado. Fallar hacer esto puede causar barrer el tornillo.

Sistema de fijar el bloqueo de leva (página 3)

Este sistema de fijar el bloqueo de leva será usado en todo el proceso ensamble.

Página 14 / 24 / 26

Coloque el Conector (6) como se muestra
Introduzca el Conector en el agujero con la ayuda de un martillo.

Página 18

No apriete por completo este tornillo.

Página 20

¡IMPORTANTE! EL PANEL TRASERO ES UNA PARTE ESTRUCTURAL DE ESTA UNIDAD Y DEBE SER INSTALADO CORRECTAMENTE.

Gire con cuidado la unidad sobre su lado frontal.

Fije el panel trasero como se muestra, clavándolo directamente en los bordes desnudos.

Asegúrese de que la unidad esté alineada.

La distancia de esquina a esquina debe ser igual a la que se muestra.

Asegúrese de que nuestra unidad esté alineada.

La distancia de esquina a esquina debe ser igual a la que se muestra.

Nivele el borde inferior del panel trasero con el borde inferior de la parte de abajo (E).

Página 22

No confunda los tornillos #8 y #11. El tornillo #8 tiene una cabeza y un cuerpo más grandes.

Página 27 / 29

Atornille en el sentido horario para fijar las piezas.

Página 31

Para mampostería, concreto o paredes de otros materiales:

Consulte en su ferretería local acerca de los anclajes apropiados para fijar correctamente el soporte de seguridad.

IMPORTANTE: ESTA UNIDAD SE DEBE FIJAR A LA PARED PARA EVITAR VOLCAMIENTOS. SIGA ESTAS INSTRUCCIONES PARA INSTALAR EL SOPORTE DE SEGURIDAD ANTIVOLCAMIENTO SUMINISTRADO CON ESTE PRODUCTO.

ADVERTENCIA

Si este mueble se voltea puede provocar lesiones graves o fatales.

Para prevenir volcamientos:

- * Instale el dispositivo de sujeción suministrado
- * Coloque los artículos más pesados en las gavetas más bajas
- * A menos que esté específicamente diseñado para ello, no coloque televisores u otros objetos pesados en la parte superior de este producto
- * Nunca permita que los niños trepen o se cuelguen de las gavetas, puertas o los estantes
- * Nunca abra más de una gaveta a la vez

El uso de los dispositivos de sujeción podría solo reducir, mas no eliminar por completo el riesgo de volcamientos

OPCIÓN 1: Fijación en un entramado de la pared (método preferido)

Mediante un buscador de entramado, localice una viga montante en la pared. Coloque su unidad contra la pared, con el soporte de seguridad alineado a dicha ubicación. Para facilitar el atornillado, podría perforar un agujero piloto de 1/8" (3 mm) de diámetro a través del soporte de seguridad y dentro del entramado. Introduzca el tornillo a través del soporte de seguridad y dentro del entramado. Apriete el tornillo que se quedó sin ser completamente apretado en el paso 9.

OPCIÓN 2: Fijación en paneles de yeso

Coloque su unidad contra la pared que desee y marque dicha pared a través del soporte de seguridad, luego haga a un lado la unidad. Perfore un agujero de 3/16" (5 mm) de diámetro a través del panel de yeso de la pared. Martille el anclaje de pared dentro del agujero hasta que quede al ras. Ponga su unidad de vuelta en su lugar y asegure el soporte de pared al anclaje con el tornillo. Apriete el tornillo que se quedó sin ser completamente apretado en el paso 9.

Página 37

Fije los rieles primero y luego la manilla.

Página 38

Nota: los agujeros de soporte de las gavetas son ranurados. Los frontales de las gavetas se pueden ajustar aflojando los tornillos, haciendo los ajustes necesarios y volviendo a apretar los tornillos.

Página 40

CARGA MAXIMA

Esta unidad ha sido diseñada para soportar las cargas máximas indicadas. Exceder estos límites de carga podría causar hundimiento, inestabilidad, colapso del producto y/o lesiones graves.

Ponga la etiqueta de advertencia de TV en su unidad para futuras referencias.

Aviso: una vez que ponga esta etiqueta en su unidad, no podrá retirarla.

Tamaño máximo del televisor (pantalla plana) 39 pulgadas

Página 41

Registre su producto para recibir lo siguiente:

- * Detalles de nuevas tendencias - Vistazo a lo nuevo
- * Encuestas - alec su voz entre su comunidad
- * Códigos de ofertas y descuentos exclusivos
- * Fácil y rápido servicio de partes de remplace

Para registrar su producto, visite ameriwoodhome.com

Clasificación de 5 estrellas

Visite el sitio web de su tienda local, califique su comprado y denos sus comentarios!

Nos gustaría enviar un gran "Agradecimiento" a todos nuestros clientes por tomarse el tiempo de ensamblar este producto de Ameriwood Home, y por darnos sus valiosos comentarios.

Gracias

Couverture Avant

CE LIVRET D'INSTRUCTION CONTIENT DES INFORMATIONS **IMPORTANTES** SUR LA SÉCURITÉ. VEUILLEZ LIRE ET GARDER POUR UNE RÉFÉRENCE FUTURE

Ne retournez pas ce produit! Contactez notre équipe de service à la clientèle amicale d'abord pour obtenir de l'aide.

Appelez-nous: 1-800-489-3351 (sans frais) du Lundi au Vendredi de 9h à 17h Heure Centrale

Visitez: www.ameriwoodhome.com

ATTENTION

Le meuble peut basculer et causer des blessures graves ou la mort.

Ancrer le meuble à une planche murale dans le mur (si indiqué).

Ne laissez pas les enfants grimper sur le meuble.

Placez les articles lourds sur les étagères ou dans les tiroirs inférieurs.

Astuces Utiles (page 2)

-Ouvrez votre article dans la zone que vous prévoyez de le garder pour moins de levage lourd

-Identifier, trier et compter les pièces avant d'essayer d'assembler

-Les goujons de compression sont taraudés avec un Marteau

-Les glissières sont marquées d'un R (droit) et d'un L (gauche) pour un bon placement

-Assurez-vous toujours de faire face la pointe situé sur le haut de la Serrure de Came vers le bord extérieur

-Utiliser tous les clous fournis pour le panneau arrière et les répartir également

-Le panneau arrière doit être utilisé pour vous assurer que votre appareil est robuste

-N'utilisez pas de produits chimiques agressifs ou de nettoyeurs abrasifs sur cet appareil

-Ne jamais pousser, tirer, ou faire glisser votre meuble

Avant de Commencer (page 3)

-Lisez attentivement chaque étape et suivez le bon ordre

-Séparez et comptez toutes vos pièces et matériaux

-Donnez-vous suffisamment de place pour l'assemblage

-Avoir les outils suivants: tournevis à tête plate, #2 tournevis Phillips, et Marteau

-Attention: Si vous utilisez une perceuse électrique ou un tournevis électrique pour visser, veillez à ralentir et arrêter lorsque la vis est bien serrée. Le non-respect de cette consigne peut endommager la vis.

Système de Fixation de Came (page 3)

Ce Système de Fixation de Came sera utilisé tout au long de l'assemblage

Français

Page 14 / 24 / 26

Positionnez le connecteur (6) comme indiqué.
Enfoncez le connecteur dans le trou à l'aide d'un marteau.

Page 18

Ne serrez pas complètement cette vis.

Page 20

IMPORTANT! LE PANNEAU ARRIÈRE EST UN ÉLÉMENT STRUCTUREL DE CE MEUBLE ET DOIT ÊTRE INSTALLÉ CORRECTEMENT.

Tournez délicatement le meuble sur sa face avant.
Fixez le panneau arrière comme indiqué en le clouant directement dans les bords bruts.
Assurez-vous que le meuble est d'équerre.
La distance d'un coin à l'autre doit être égale, comme indiqué.

Assurez-vous que notre meuble est d'équerre.
La distance d'un coin à l'autre doit être égale, comme indiqué.

Alignez le bord inférieur du panneau arrière avec le bord inférieur du fond (E).

Page 22

Ne mélangez pas les vis # 8 et # 11. La vis # 8 a une tête et un corps plus grands.

Page 27 / 29

Faites tourner la vis dans le sens des aiguilles d'une montre pour assembler solidement les pièces.

Page 31

Pour les murs en maçonnerie, en béton ou autres matériaux :

Consultez votre quincaillerie locale pour obtenir des ancrages muraux adaptés afin de fixer solidement l'entretoise de sécurité.

IMPORTANT : CE MEUBLE DOIT ÊTRE FIXÉ AU MUR POUR ÉVITER TOUT BASCULEMENT. SUIVEZ CES INSTRUCTIONS POUR INSTALLER L'ENTRETOISE DE SÉCURITÉ ANTIBASCULEMENT FOURNIE AVEC CE PRODUIT.

AVERTISSEMENT

Le basculement d'un meuble peut entraîner des blessures graves ou mortelles par écrasement.

Pour éviter tout basculement :

- * Installez le dispositif de retenue antibasculement fourni.
- * Placez les objets les plus lourds dans les tiroirs du bas.
- * Ne posez pas de téléviseurs ou d'autres objets lourds sur le dessus de ce produit, à moins qu'il n'ait été spécifiquement conçu à cet effet.
- * Ne laissez jamais les enfants grimper sur les tiroirs, la porte ou les étagères, ou s'y suspendre.
- * N'ouvrez jamais plus d'un tiroir à la fois.

Il est possible que l'utilisation de dispositifs de retenue antibasculement ne fasse que réduire le risque de basculement, mais ne l'élimine pas.

OPTION 1 : fixation à un poteau mural (méthode préférée)

À l'aide d'un détecteur de montants, trouvez un poteau dans le mur. Placez votre meuble contre le mur, avec l'entretoise de sécurité alignée sur cet endroit. Pour faciliter le vissage, vous pouvez percer dans le poteau un trou de guidage d'un diamètre de 3 mm (1/8") à travers l'entretoise de sécurité. Vissez la vis dans le poteau mural à travers l'entretoise de sécurité. Serrez la vis qui ne l'avait pas été entièrement lors de l'étape 9.

OPTION 2 : fixation dans une cloison sèche

Placez votre meuble contre un mur à l'endroit de votre choix et faites-y une marque à travers l'entretoise de sécurité, puis déplacez votre meuble sur le côté. Percez un trou de 5 mm (3/16") de diamètre dans le panneau mural. Enfoncez l'ancrage mural dans le trou jusqu'à ce qu'il soit affleurant. Mettez votre meuble en place et fixez l'entretoise murale à l'ancrage murale à l'aide de la vis. Serrez la vis qui ne l'avait pas été entièrement lors de l'étape 9.

Page 37

Fixez d'abord les glissières, puis la poignée.

Page 38

Remarque : les trous de support du tiroir sont fendus. Les bandeaux de tiroir peuvent être ajustés en desserrant les vis, en apportant les ajustements nécessaires, puis en resserrant les vis.

Page 40

CHARGES MAXIMALES

Ce meuble a été conçu pour supporter les charges maximales indiquées. Le dépassement de ces limites pourrait entraîner un affaissement, une instabilité, un effondrement du produit et/ou des blessures graves.

Appelez sur votre meuble l'étiquette d'avertissement en matière de téléviseurs afin de pouvoir vous y référer ultérieurement.

Remarque : une fois cette étiquette apposée sur votre meuble, vous ne pouvez plus la retirer.

Taille maximale du téléviseur (écran plat) : 99 cm.

Page 41

Enregistrez votre produit pour recevoir les éléments suivantes:

- * Détails sur les nouvelles tendances - un aperçu sur les nouveautés
- * Sondages - avoir une voix au sein de notre communauté
- * Offres exclusives et codes promo
- * Service de pièces de rechange rapide et facile

Pour enregistrer votre produit, visitez ameriwoodhome.com

5 Étoiles

Visitez le site Web de votre détaillant local, évaluez votre produit acheté et laissez-nous quelques commentaires !

Nous tenons à offrir un grand "Merci" à tous nos clients pour avoir pris le temps d'assembler ce produit "Ameriwood Home", et de nous donner vos commentaires précieux.

Merci